

Magnum® XT-90

Hermetically Sealed Proximity Sensor (Simple Apparatus)

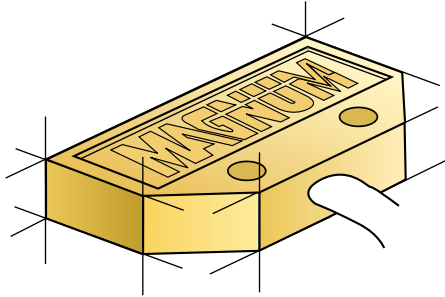

Valox® Housing

Tungsten Contacts

Hermetic Seal (Glass)

3 Conductor PVC Insul.

Acid/Alkali Resistant

Ultrasonic Weld

Epoxy Resin

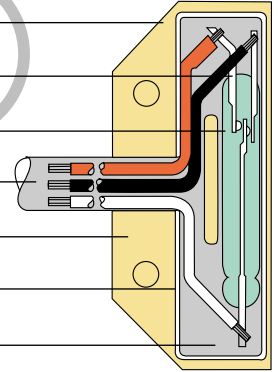

2 - SPDT Magnum Sensors with 8 Point Terminal Strip

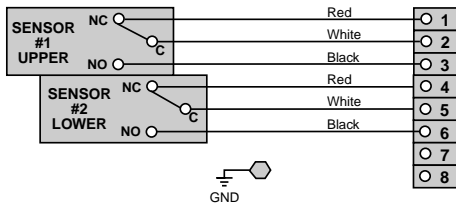

4 - SPDT Magnum Sensors with 16 Point Terminal Strip

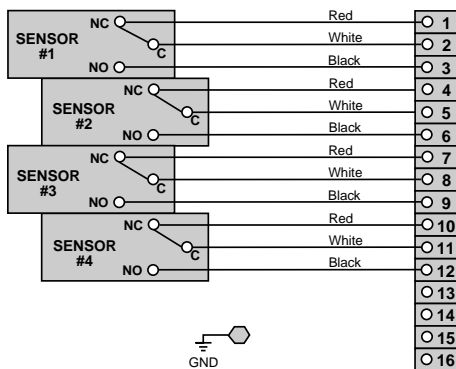

2 - SPST Magnum Sensors with 8 Point Terminal Strip

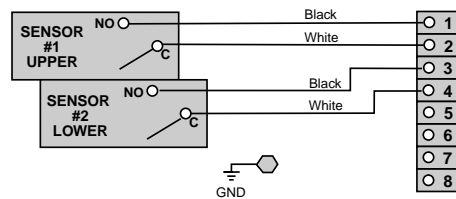

2 - SPDT Magnum Sensors with Solenoid & 8 Point Terminal Strip

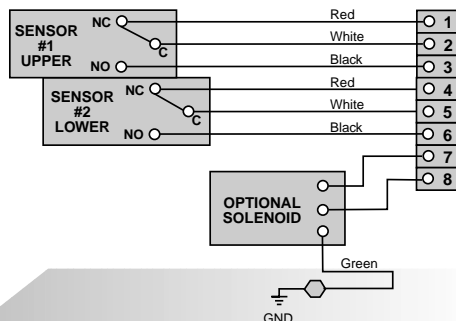

Technical Data

| | |
|----------------------------|----------------------------------|
| Contact Arrangement | SPDT, Form C (Normally Open) |
| Contacts | Pure Tungsten |
| Operating Time | 3.0 m Sec. |
| Initial Contact Resistance | .50 ohms (Max) |
| Seal | Hermetic |
| Housing (Flame Retardant) | High Impact Valox® |
| Approvals | UL, CSA |
| Temperature Range | -40°F to +185°F |
| Operational Life | 600,000 Cycles (full rated load) |
| Repeatability | .125 mm. |
| Warranty | 5 Years |
| Protection Class | IP 67 |
| Electrical Rating | |
| Contact Arrangement | SPDT Form C (Normally Open) |
| | 3 amps/120 VAC, 1.5 amps/240 VAC |
| | 2 amps/24 VDC |

DIMENSIONS (mm)

