

Quantum®

Wiring Diagrams

2-SPDT Mechanical Switches with Falcon Solenoid & 8 PT TS

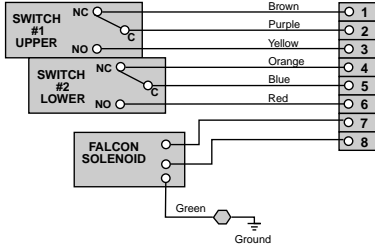

2-SPST Mechanical Switches with Falcon Solenoid & 8 PT TS

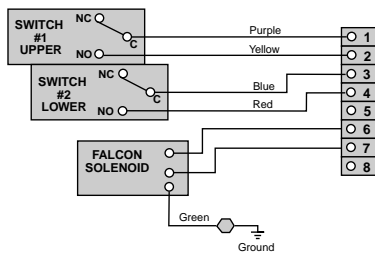

2-DPDT Mechanical Switches with Falcon Solenoid & 16 PT TS

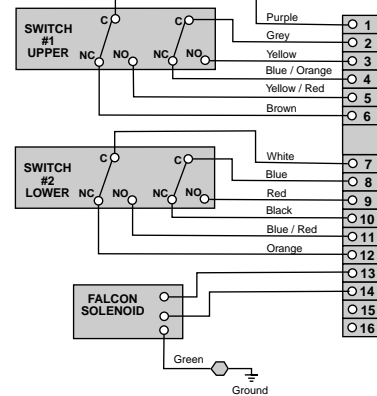

2-SPDT Mechanical Switches with Falcon Dual Coil Solenoid & 10 PT TS

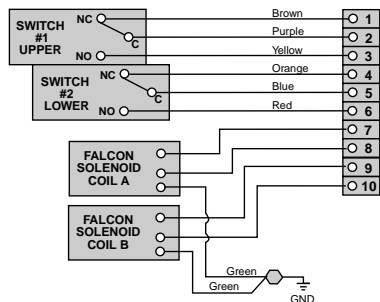

2-SPST Mechanical Switches with Falcon Dual Coil Solenoid & 8 PT TS

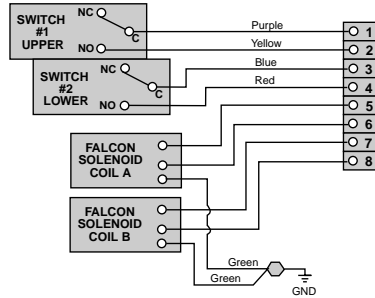

2-DPDT Mechanical Switches with Falcon Dual Coil Solenoid & 16 PT TS

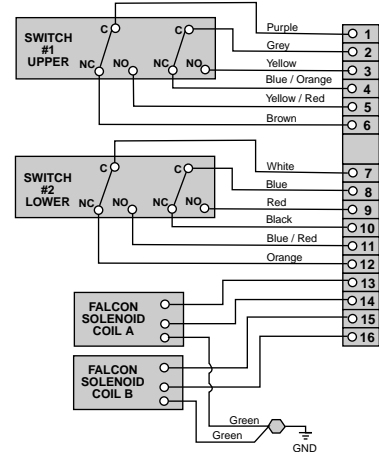

2-SPDT Magnum Sensors with Falcon Solenoid & 8 PT TS

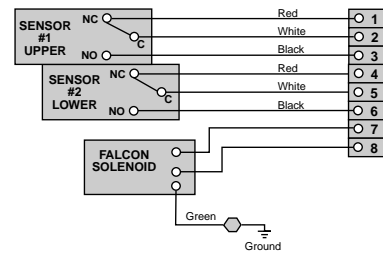

2-SPST Magnum Sensors with Falcon Solenoid & 8 PT TS

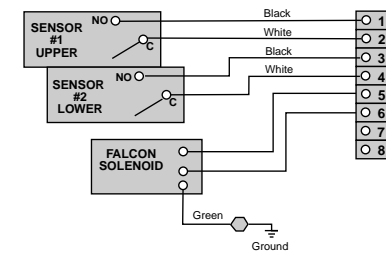

P+F Kriterion Sensor with Falcon Solenoid & 8 PT TS

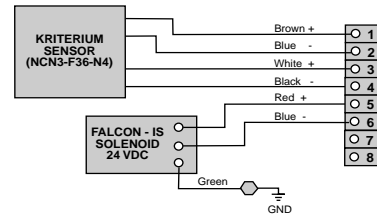

2-SPDT Magnum Sensors with Falcon Dual Coil Solenoid & 12 PT TS

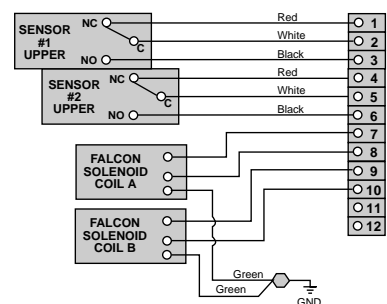

2-SPST Magnum Sensors with Falcon Dual Coil Solenoid & 8 PT TS

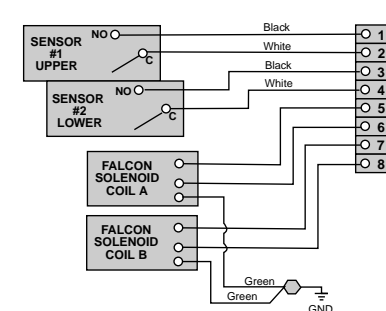

P+F Kriterion Sensor with Falcon Dual Coil Solenoid & 10 PT TS

