



A Cost Efficient Integrated System to Monitor and Regulate Valves in a Single Assembly

## Eliminator® 3000 Explosionproof

Engineering and plant personnel may now specify an extremely reliable, cost efficient system to monitor and regulate valves in one compact assembly. Westlock Controls design engineers have successfully combined three separate products: a junction box, a limit switch, and a solenoid valve into a single unit — the first of its kind to be listed and recognized as a single assembly by Underwriters Laboratory for hazardous area applications.

The Eliminator is a highly reliable valve position monitor and prewired, integrally mounted ASCO® solenoid valve. Compatible with all PC's, the 3000 series is available with mechanical or proximity switches and a broad selection of solenoid valves. The high cost of independent junction boxes, mandatory wiring, seal fittings and field labor is totally eliminated.

### COMPARATIVE COST ANALYSIS

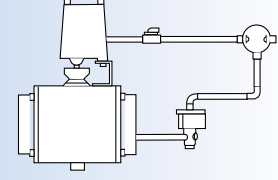
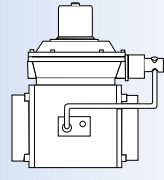
MECHANICAL SWITCHES			
			
CONVENTIONAL METHOD		ELIMINATOR® 3000	
2 Switches	\$150.	2 Switches	Included
Solenoid	100.	Solenoid	Included
Junction Box	50.	Junction Box	Included
Seal Fittings	40.	Seal Fittings	NR* <sup>1</sup>
Wire, Conduit	20.	Wire, Conduit	NR*
Labor	170.	Labor	NR*
<b>TOTAL COST</b>	<b>\$530.</b>	<b>TOTAL COST</b>	<b>\$298.</b>

\*Not Required

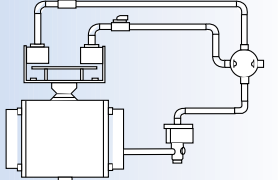
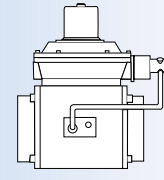
PROXIMITY SENSORS			
			
CONVENTIONAL METHOD		ELIMINATOR® 3000	
2 Switches	\$358.	2 Sensors	Included
Solenoid	100.	Solenoid	Included
Junction Box	50.	Junction Box	Included
Seal Fittings	80.	Seal Fittings	NR* <sup>1</sup>
Wire, Conduit	30.	Wire, Conduit	NR*
Labor	270.	Labor	NR*
<b>TOTAL COST</b>	<b>\$888.</b>	<b>TOTAL COST</b>	<b>\$364.</b>

<sup>1</sup> A seal fitting between the Asco solenoid and Eliminator enclosure is not required

\*Not Required

# Eliminator® 3000

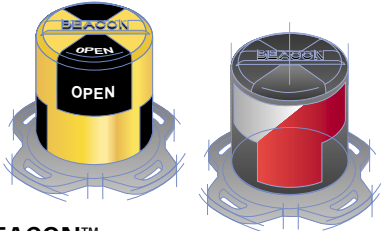

## BEACON™

An impact and corrosion resistant valve position monitor capable of displaying exact valve position from any quadrant at distances of up to 150 feet. Start-up and operating personnel avoid being placed in physically awkward or dangerous situations while attempting to ascertain valve position.

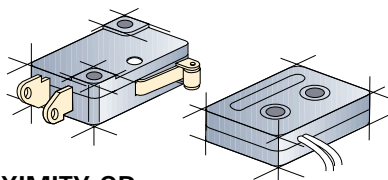

## PROXIMITY OR MECHANICAL SENSORS

Switch requirements will differ with operating conditions in the industrial environment. Mechanical switches are less expensive and possess the highest current rating. Proximity sensors, encapsulated and hermetically sealed against explosive gases and liquids, provide maximum moisture and corrosion resistance. The reed type proximity sensor eliminates contact bounce while being totally compatible with all computers and PCs.

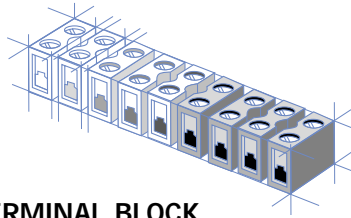

## TERMINAL BLOCK

The Eliminator® features an elevated prewired terminal block with two additional points for solenoid valve integration. The enclosure additionally functions as a junction box.

## TOUCHSET™ CAMS

Cams, secured by set screws, continually lose calibration due to vibration inherent in all pipelines. Self-locking Touchset™ cams are fastened to a splined shaft and can be set by hand in seconds. Since there are no set screws, the cams will never slip out of adjustment.

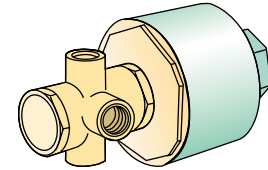
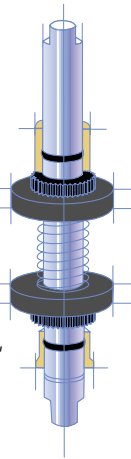

## ASCO SOLENOID

Asco is the undisputed choice of the process control industry. Specified by engineers and plant personnel worldwide, the ASCO solenoid valve has proven reliable in millions of industrial applications.

## AGENCY LISTING

Underwriters Laboratory has long been recognized for its uncompromising commitment to human safety. Insurance underwriters, government authorities, engineers and plant operators regard the the UL listing and Classification Mark as evidence that the product has satisfied the strictest safety requirements. The Westlock Eliminator has been evaluated and listed by UL and CSA as a single assembly, rather than an arbitrary combination of unrelated components.

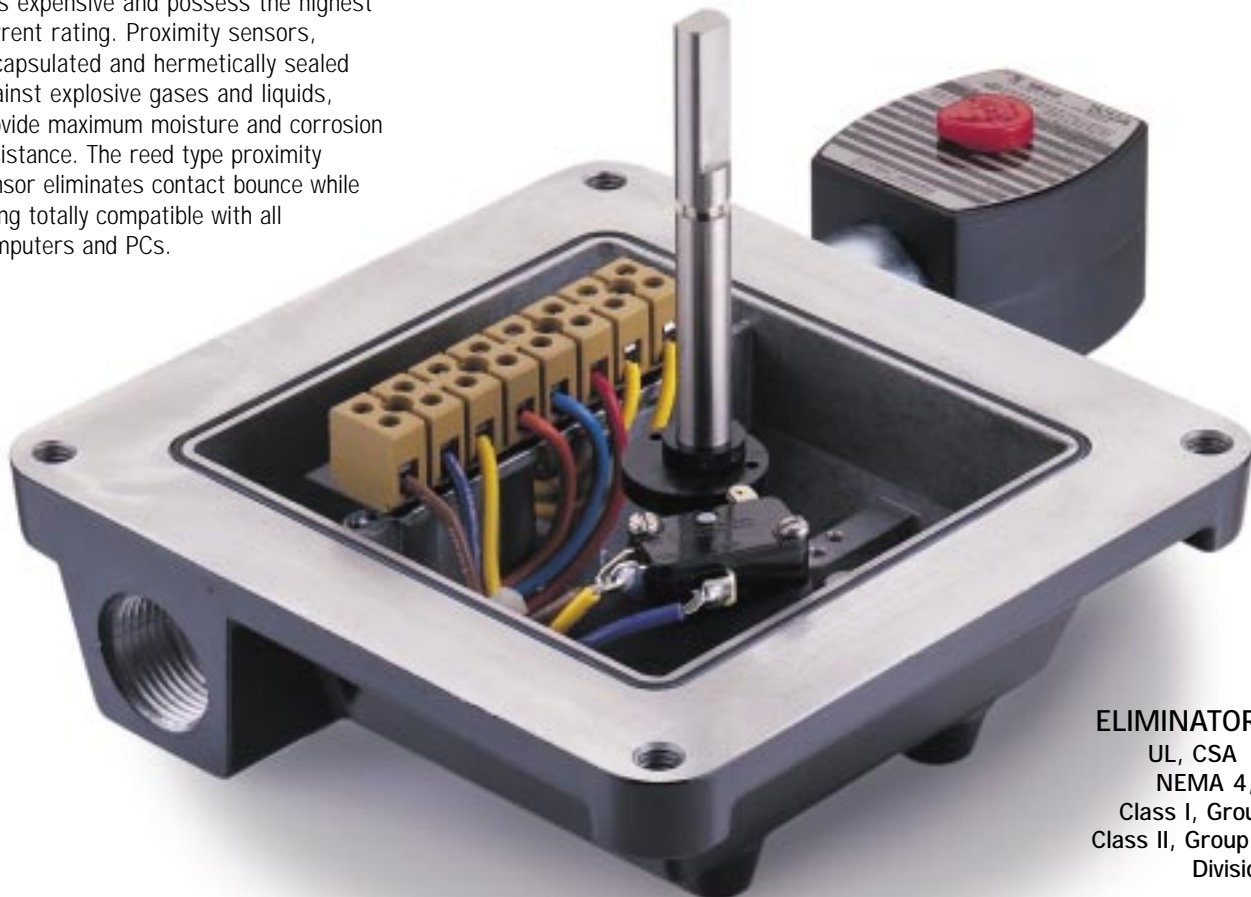

## ELIMINATOR™ 3000

UL, CSA Listed for  
NEMA 4, 4X, 7, 9  
Class I, Groups C & D  
Class II, Group E, F & G,  
Divisions 1 & 2

# Eliminator<sup>®</sup> 3000

## Standard Sensor Options

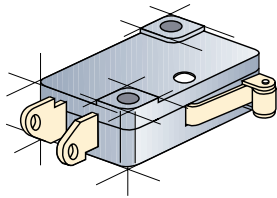

### Mechanical Switches

UL, CSA Listed



AMPS	SPDT (V3)		DPDT (Licon)	
	VAC	VDC	AMPS	VAC
15	125		10	125
15	250		10	250
10		24		
.50		125		
.25		250		

### Proximity Sensors UL, CSA

- All switches are PC compatible
- Platinum plated magnetic reed
- Hermetically sealed in glass
- Doubly sealed in silicon housing
- Repeatability: .002 inches
- Switch Life: 100,000,000 cycles

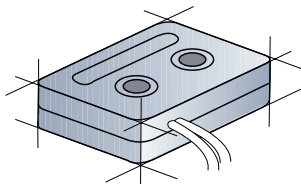

	SPST	SPDT
Actuation Time (milli-seconds)	.5	1.5
Contact Resistance (ohms)	.100	.150
Contact Rating* (AC, DC) (Watts)	10	3
Volts (max) (AC, DC)	200	200
Amps (max) (switching)	.5	.25
Amps (max) (carry)	1.2	1.2
Switch Temp. Rating (°F)	200	200

\* Resistive: Reduce rating to 1/3 for inductive loads.

## 0-100% Position Transmission

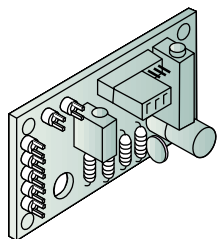
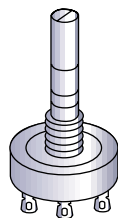

### Resistive Output Signal

Standard Output Signal	1000 ohms
Power Rating at 70°C	1 watt
Elements	Conductive Plastic
Rotational Life (no load)	100,000 cycles

### Current Output Signal

Standard Output Signal	4-20 mA DC, 2 wire
Power Requirements	5-38 VDC
Max. Load Resistance at 24 VDC	950 ohms
Operating Temperature	-24°C to 85°C

# AccuTrak® 3000

### AREA CLASSIFICATIONS

NEMA 4, 4x, 7, 9  
 Class I, Groups C, D  
 Class II, Groups E, F, G,  
 Divisions 1 & 2

### ENCLOSURE

Conduit Entries 1-3/4" NPT, 1-1/2" NPT  
 Terminal Strip 8 contacts standard  
 16 contact available

### MATERIALS OF CONSTRUCTION

Housing	Die Cast Aluminum
Cover	Die Cast Aluminum
Shaft	Stainless Steel
Fasteners	Stainless Steel
Beacon	Copolyester

### APPROVALS / CERTIFICATION

**UL** (Underwriters Laboratories, Inc.)  
**CSA** (Canadian Standards Association)

### DIMENSIONS (inches/mm)

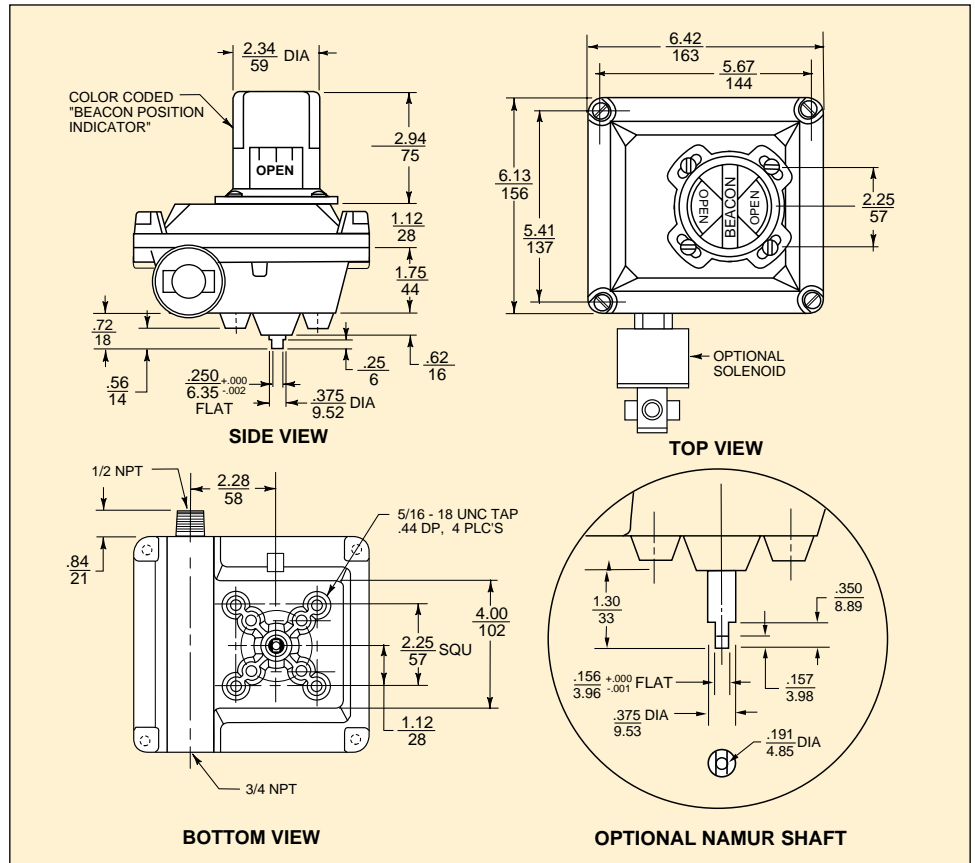

### ORDERING GUIDE

ENCLOSURE	BEACON™	3-WAY BEACON™	TRANSMITTER	SOLENOID
<b>3030</b> Mechanical Switches SPDT or DPDT  UL SF	<b>STANDARD</b> (Black & Yellow) <b>BY</b> 	<b>90° Rotation</b>  <b>B1</b>	1000 ohms <b>RS</b>	<b>ASCO</b> To Be Specified By Customer 
	<b>ANSI YELLOW</b> (Inherently Hazardous) <b>AY</b> 	<b>90° Rotation</b>  <b>B3</b>	4-20 mA <b>CS</b>	
	<b>ANSI GREEN</b> (Liquid-Low Hazard) <b>AG</b> 	<b>90° Rotation</b>  <b>B5</b>		
<b>3057</b> Proximity Sensors SPST or SPDT  UL SF	<b>ANSI BLUE</b> (Gas-Low Hazard) <b>AB</b> 	<b>180° Rotation</b>  <b>B7</b>		
	<b>ANSI RED</b> (Fire Quenching) <b>AR</b> 	<b>180° Rotation</b>  <b>B9</b>		

**Ordering Example:** Eliminator with 2 proximity sensors and standard black and yellow Beacon. 3057-BY with 2 SPDT and Asco 8320A90.

**Options Available:** The 3000 Series is available with up to six switches and four separate conduit entries. Special coatings, special features of ASCO valves are available upon request.