

Series 240 and 250

Pneumatic control valves with AC-1 or AC-2 Trim



Application

Optimized trim for **low-noise and low-wear pressure reduction for liquids with differential pressures up to 40 bar**

Nominal size DN 50 to 300 · 2" to 12"

Nominal pressure PN 16 to 160 · Class 150 to 900

Temperature range -10 to 220 °C · 14 to 428 °F



The **AC-1** Trim includes the following special features:

- Raised seat
- Parabolic plug with integrated guide in the seat.

One to four attenuation plates are integrated into seat of the **AC-2** Trim upstream of the parabolic plug and the plug guide.

The differential pressure may not exceed 40 bar or 580 psi.

Versions

Standard version for SAMSON valves acc. to Tables 2 and 3

- **AC-1** · Optimized trim for valve sizes DN 50 to 300 or 2" to 12"
- **AC-2** · Optimized trim with one to four attenuation plates for valve sizes DN 80 to 250 or 3" to 10"

Other versions

Pressure-balanced version on request

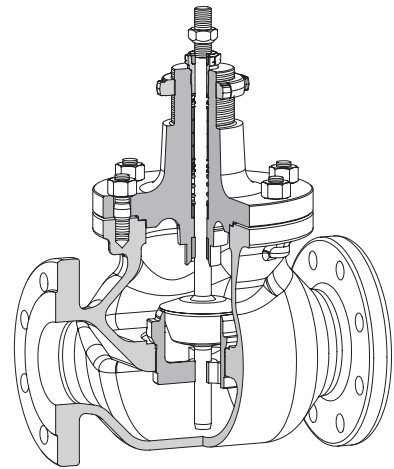

Fig. 1 · Type 3251 Valve with AC-1 Trim

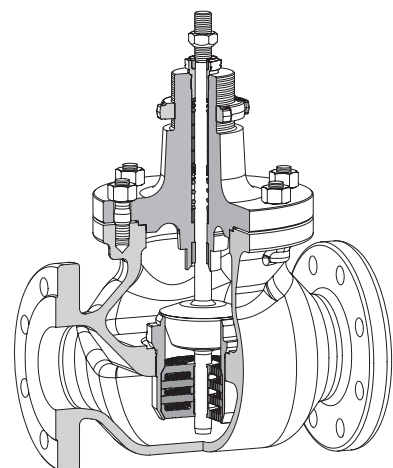

Fig. 2 · Type 3251 Valve and
AC-2 Trim with four attenuation plates

Principle of operation

The medium flows through the valve against the closing direction of the plug. The valve plug determines the cross-sectional area of flow. The K_V value is adapted over the plug and, if necessary, using a combination of attenuation plates upstream of the seat.

To avoid vibrations, the plug is double guided by a guide bushing at the top and a second guide in the seat.

AC-1

Compared to standard valve trims, these trims considerably reduce the sound pressure level for differential pressure ratios between $X_F = 0.25$ and $X_F = 0.75$ by shifting the point of incipient cavitation.

Depending on the valve load, the sound pressure level is reduced to varying degrees.

AC-2

Optionally one to four attenuation plates can be integrated in the seat on the upstream side. In this way, the point of incipient cavitation is shifted at large valve loads to higher differential pressure ratios X_F .

For small valve loads, the onset of cavitation is shifted by higher X_{Fz} values of the parabolic plug to higher differential pressure ratios.

Compared to standard valve trims, these trims considerably reduce the sound pressure level for differential pressure ratios between $X_F = 0.25$ and $X_F = 0.9$ by shifting the point of incipient cavitation.

The differential pressure ratio X_F is defined as

$$X_F = \frac{\Delta p}{p_1 - p_v}$$

with Δp being the differential pressure across the valve, p_1 being the upstream pressure, and p_v representing the vapor pressure of the medium.

The reduction of the sound pressure level $\Delta L_{p_{Aa}}$ compared to a standard valve trim is exemplified in Figs. 5 and 6. The diagrams illustrate four different valve loads.

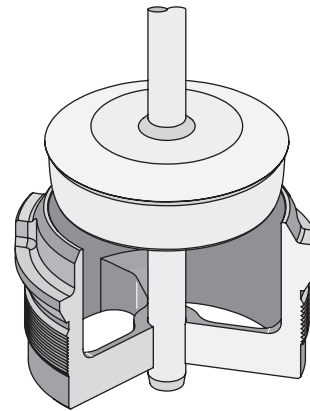

Fig. 3 · Sectional view of AC-1 Trim

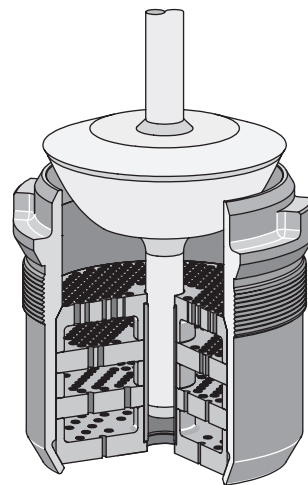

Fig. 4 · Sectional view of AC-2 Trim with four attenuation plates

Table 1 · Technical data for AC-1 Trim and AC-2 Trim

	AC-1	AC-2
Nominal size	DN 50 to 300 · 2" to 12"	DN 80 to 250 · 3" to 10"
Nominal pressure	PN 16 to 160 · Class 150 to 900	
Temperature range	-10 to 220 °C · 14 to 428 °F	
Δp_{max} Max. perm. differential pressure	Operation without cavitation: < 40 bar · < 580 psi	
	Operation with cavitation: < 25 bar · < 360 psi	
Medium	Liquids only	
Direction of flow	Flow-to-open (FTO) only	
Closure member	Double-guided parabolic plug	Double-guided parabolic plug with attenuation plates integrated into the seat
Seat-plug seal	Metal sealing: Class IV	
Leakage class (DIN EN 1349)	IV-S1 for SB ≥ 100 · IV-S2 for SB < 100	
K_V/C_V value	See Table 2	See Table 3
Characteristic	Equal percentage	Equal percentage modified
Rangeability	50 : 1	See Table 3
Seat bore	See Table 2	See Table 3
Travels	See Table 2	See Table 3
Trim materials	1.4571 Stellite hard facing/1.4006 Stellite hard facing/1.4301	

Reduction of the sound pressure level

The diagrams illustrate the reduction of the sound pressure level ΔL_{pa} when using the AC Trims as opposed to a standard trim.

ΔL_{pa} values of other AC Trims available on request.

Figs. 5 and 6 · Nominal size DN 80 (3") and DN 150 (6")

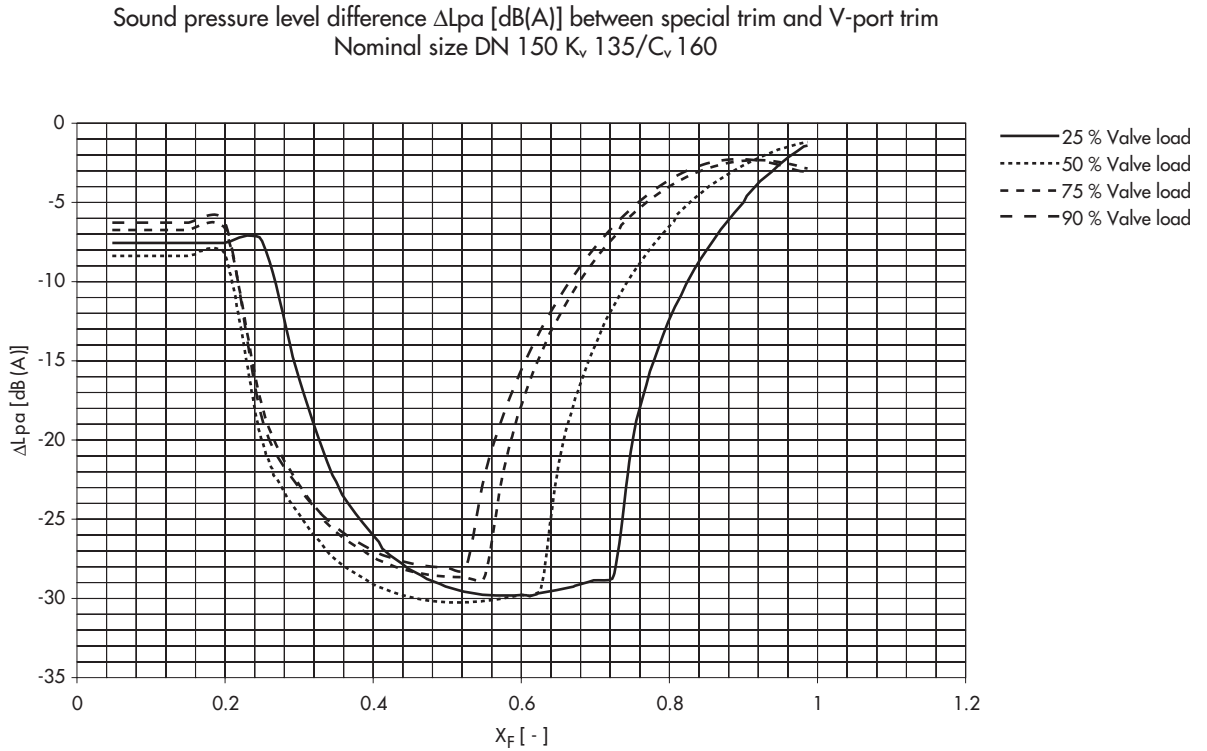
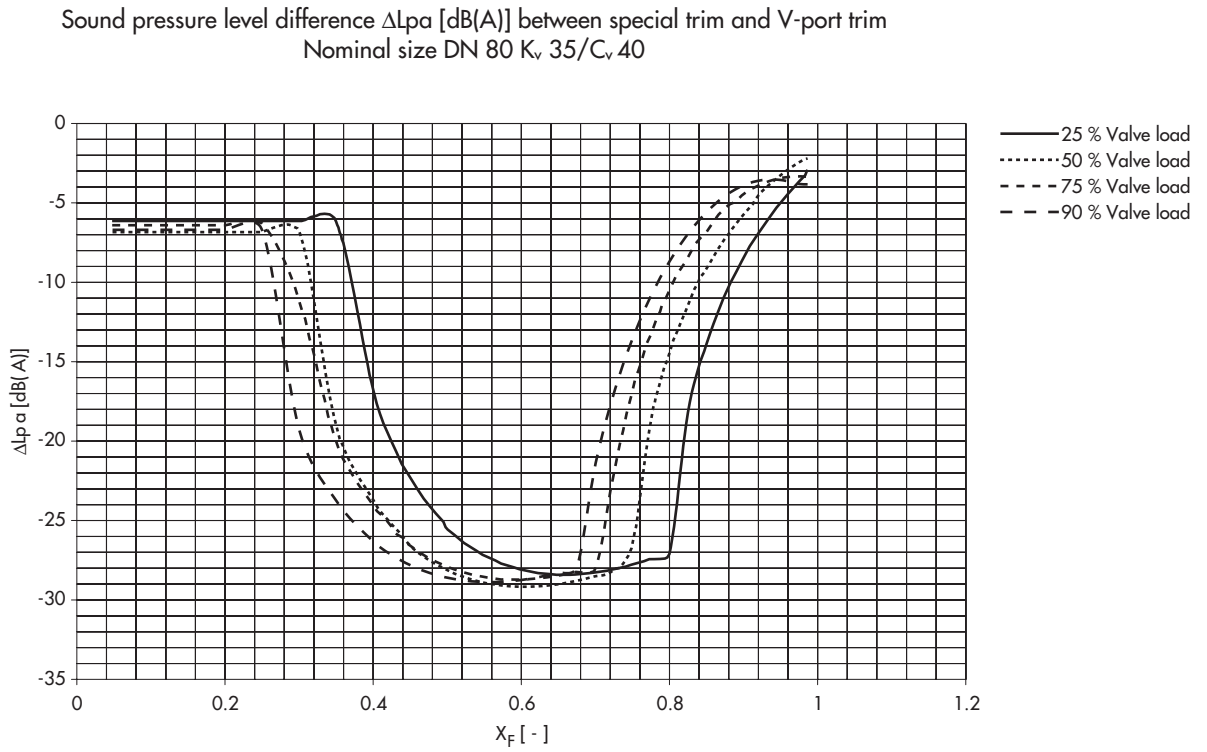

Table 2 · AC-1 Trim · Nominal sizes and their associated flow coefficients (K_V and C_V)

The specified travels must be achieved including an overtravel of 10 %.

The use of a mechanical travel stop is required for actuators with fail-safe action "stem extends".

DN/in	SB [mm]	Travel [mm]	K _V	C _V	Valve Type	X _{fz} value [Valve load %]
DN 50 2"	48	15	35	40	3241	0.34 (90 %)
	50	30			3251/3256	0.38 (75 %) 0.45 (50 %) 0.54 (25 %)
DN 80 3"	48	15	35	40	3241	0.34 (90 %)
	50	30			3251/3256	0.38 (75 %) 0.45 (50 %) 0.54 (25 %)
	63	15	50	60	3241	0.31 (90 %)
		30			3251/3256	0.35 (75 %) 0.44 (50 %) 0.56 (25 %)
	80	30	60	70	3251 3256	0.38 (90 %) 0.42 (75 %) 0.49 (50 %) 0.60 (25 %)
			70	80		0.35 (90 %) 0.38 (75 %) 0.47 (50 %) 0.58 (25 %)
DN 100 4"	48	15	38	45	3241	0.33 (90 %)
	50	30			3251/3256	0.36 (75 %) 0.43 (50 %) 0.53 (25 %)
	63	30	55	65	3241	0.29 (90 %)
					3251/3256	0.33 (75 %) 0.42 (50 %) 0.54 (25 %)
	80	30	75	90	3241	0.33 (90 %)
					3251/3256	0.37 (75 %) 0.45 (50 %) 0.57 (25 %)
	100	30	75	90	3251/3256	0.42 (90 %) 0.46 (75 %) 0.53 (50 %) 0.63 (25 %)
			100	120	3241	0.37 (90 %)
		100	120	3251/3256	0.40 (75 %) 0.48 (50 %) 0.59 (25 %)	
DN 150 6"	80	30	95	110	3241	0.27 (90 %)
					3251/3256	0.32 (75 %) 0.41 (50 %) 0.53 (25 %)
	100	30	145	170	3241/3251/3256	0.28 (90 %) 0.32 (75 %) 0.41 (50 %) 0.54 (25 %)
					3241	0.25 (90 %)
	125	30	205	240	3251/3256	0.29 (75 %)
		60				0.38 (50 %) 0.50 (25 %)
	150	60	205	240	3251 3256	0.34 (90 %) 0.37 (75 %) 0.45 (50 %) 0.57 (25 %)
			250	290		0.28 (90 %) 0.33 (75 %) 0.41 (50 %) 0.54 (25 %)

DN/in	SB [mm]	Travel [mm]	K _v	C _v	Valve Type	X _{fz} value [Valve load %]
DN 200 8"	100	30	155	180	3241 3251 3256	0.27 (90 %) 0.31 (75 %) 0.40 (50 %) 0.53 (25 %)
	125	60	230	270		0.22 (90 %) 0.26 (75 %) 0.36 (50 %) 0.49 (25 %)
	150	60	305	360		0.24 (90 %) 0.28 (75 %) 0.37 (50 %) 0.51 (25 %)
	200	60	360	420		0.33 (90 %) 0.37 (75 %) 0.45 (50 %) 0.57 (25 %)
			480	560		0.26 (90 %) 0.31 (75 %) 0.40 (50 %) 0.52 (25 %)
DN 250 10"	100	30	155	180	3241 3254	0.27 (90 %) 0.31 (75 %) 0.40 (50 %) 0.53 (25 %)
	125	60	230	270		0.22 (90 %) 0.26 (75 %) 0.36 (50 %) 0.49 (25 %)
	150	60	305	360		0.24 (90 %) 0.28 (75 %) 0.37 (50 %) 0.51 (25 %)
	200	60	360	420		0.33 (90 %) 0.37 (75 %) 0.45 (50 %) 0.57 (25 %)
			480	560		0.26 (90 %) 0.31 (75 %) 0.40 (50 %) 0.52 (25 %)
DN 300 12"	125	60	230	270	3241 3254	0.22 (90 %) 0.26 (75 %) 0.36 (50 %) 0.49 (25 %)
	150	60	305	360		0.24 (90 %) 0.28 (75 %) 0.37 (50 %) 0.51 (25 %)
	200	60	480	560		0.26 (90 %) 0.31 (75 %) 0.40 (50 %) 0.52 (25 %)
	250	120	1000	1150		0.20 (90 %) 0.24 (75 %) 0.33 (50 %) 0.48 (25 %)

Table 3 · AC-2 Trim · Nominal sizes and their associated flow coefficients (K_V and C_V)

The specified travels must be achieved including an overtravel of 10 %.

The use of a mechanical travel stop is required for actuators with fail-safe action "stem extends".

DN/in	SB [mm]	Travel [mm]	K _V	C _V	Valve Type	Attenuation plate		Range-ability
						Quantity	Bore Ø	
DN 80 3"	80	30	16	20	3251	4	3	>10:1
			22	25				>15:1
			25	30				>20:1
			30	35				>25:1
			35	40				
			38	45				
			43	50				
DN 100 4"	100	30	50	60	3251	4	3	>20:1
			35	40				>15:1
			38	45				>10:1
			43	50				
			45	55				
			50	60				
			55	65				
DN 150 6"	150	60	60	70	3251	3	5	>15:1
			63	75				>20:1
			60	70				>30:1
			72	85				>20:1
			85	100				
			95	110				
			100	120				
DN 200 8"	200	60	110	130	3241 3251	4	5	>15:1
			120	140				>10:1
			130	150				>15:1
			135	160				
			145	170				
			155	180				
			160	190				
DN 250 10"	200	60	160	190	3241	4	5	>20:1
			180	210				>15:1
			180	210				
			190	220				
			205	240				
			220	255				
			250	290				
DN 200 8"	200	60	260	305	3241	3	5	20:1
			280	325				>20:1
			320	375				>20:1
			220	255				>25:1
			250	290				
			260	305				
			280	325				
DN 250 10"	200	60	320	375	3241	2	5	>15:1
			135	160				>10:1
			145	170				>15:1
			155	180				
			160	190				
			170	200				
			180	210				
DN 200 8"	200	60	190	220	3241	1	5	20:1
			205	240				>20:1
			220	255				>20:1
			250	290				>25:1
			260	305				
			280	325				
			320	375				

Table 4 · Permissible differential pressures for Series 240 Valves with a AC-1 or AC-2 Trim

Table 4a · Valves with fail-safe position "Valve CLOSED" (FA) · Differential pressures >40 bar for ANSI version only

Bench range in bar with actuator size in cm ²				240	0.3...1.1	0.6...2.2	0.9...3.3	–	–	–		
				350/700	0.4...1.2	0.8...2.4	1.2...3.6	1.4...2.3	21...3.3			
				700	(0.8...1.2)	(1.6...2.4)	(2.4...3.6)	–	–	2.6...4.3	2.7...3.3	–
				1400	0.8...1.2	0.8...2.4	1.0...3.0	1.4...2.7	1.7...3.2	2.0...3.0	2.05...2.7	2.45...3.2
				2800	1.25...2.3	1.5...3.0	1.6...2.4	1.8...3.8	2.0...3.0	2.4...3.2	2.8...3.8	3.0...3.6
				2x2800	5	–	–	–	–	–	–	–
Required supply pressure				Upper spring range value + 0.2 bar								
DN	Kvs	SB	Actuator in cm ²	Δp when p ₂ = 0 bar								
DN 50	35	48	350	6	11.9	17.9	20.8	31.2	–	–	–	
			700	(23.8)	–	–	–	–	–	–	–	
DN 80	35	48	350	6	11.9	17.9	20.8	31.2	–	–	–	
	50	63		3.5	6.9	10.4	12.1	18.1	–	–	–	
	35	48	700	(23.8)	(47.6)	–	–	–	–	–	–	
	50	63		(13.8)	(27.6)	–	–	–	–	–	–	
DN 80 PN 40	35	48	700	(23.8)	(47.6)	(50)	–	–	–	50	–	
	50	63		(13.8)	(27.6)	(41.5)	–	–	–	46.6	–	
DN 100	38	48	350	6	11.9	17.9	20.8	31.2	–	–	–	
			700	(23.8)	(47.6)	(50)	–	–	–	(50)	–	
	55	63	700	6.9	13.8	20.7	24.2	36.3	44.9	–	–	
	75	80		4.3	8.6	12.9	15	22.5	27.9	–	–	
DN 100 PN 40	55	63	1400	27.6	–	–	–	–	50	50	50	
	75	80		17.1	–	–	–	–	42.8	43.9	50	
	100	100		11	–	–	–	–	27.4	28.1	33.6	
DN 150	95	80	700	4.3	8.6	12.9	15	22.5	27.9	–	–	
	145	100		2.7	5.5	8.2	9.6	14.4	17.8	–	–	
	205	125		1.8	3.5	5.3	6.1	9.2	11.4	–	–	
DN 150 PN 40	95	80	1400	17.1	–	–	–	–	42.8	43.9	50	
	145	100		11	–	–	–	–	27.4	28.1	33.6	
	205	125		7	–	–	–	–	17.6	18	21.5	
DN 200 und DN 250	155	100	1400	11	–	–	–	–	27.4	28.1	33.6	
	230	125		–	7	8.8	12.3	14.9	–	–	–	
	305	150		–	4.9	6.1	8.5	10.4	–	–	–	
	135...480	200		–	2.7	3.4	4.8	5.8	–	–	–	
	155	100	2800	–	–	–	–	–	–	–	50	
	230	125		–	–	28.1	–	35.1	42.1	49.1	–	
	305	150		–	–	19.5	–	24.4	29.3	34.1	–	
135...480	200	–	–	11	–	13.7	16.5	19.2	–	–		
DN 200/250 PN 40	230	125	2x2800	–	–	50	–	50	50	–	–	
	305	150		–	–	39	–	48.8	50	–	–	
	135...480	200		–	–	21.9	–	27.4	32.9	–	–	
DN 300	230	125	1400	–	7	8.8	12.3	14.9	–	–	–	
	305	150		–	4.9	6.1	8.5	10.4	–	–	–	
	480	200		–	2.7	3.4	4.8	5.8	–	–	–	
	1000	250		–	1.8	2.2	3.1	3.7	–	–	–	
	230	125	2800	–	–	28.1	–	35.1	42.1	49.1	–	
	305	150		–	–	19.5	–	24.4	29.3	34.1	–	
	480	200		–	–	11	–	13.7	16.5	19.2	–	
	1000	250		5.5	6.6	–	7.9	–	–	–	–	

Table 4b · Series 240 Valves with fail-safe position "Valve OPEN" (FE) · Differential pressures >40 bar for ANSI version only

Bench range in bar with actuator size (cm ²)				240	0.2 ... 1.0				
				350/700					
				700	0.2 ... 0.6				
				1400					
				2800	0.4 ... 2.0 (0.3 ... 1.1)				
				2x2800					
Required supply pressure				1.4	2.4	3.6	4	6	
DN	Kvs	SB	Actuator in cm ²	Δp when p ₂ = 0 bar					
DN 50	35	48	350	6	20.8	38.7	–	–	
			700	(23.8)	–	–	–	–	
DN 80	35	48	350	6	20.8	38.7	44.6	–	
	50	63		3.5	12.1	22.5	25.9	–	
	35	48		6	20.8	38.7	44.6	–	
	50	63		3.5	12.1	22.5	25.9	–	
DN 80 PN 40	35	48	700	(23.8)	(50)	(50)	(50)	–	
	50	63		(13.8)	(31.1)	(50)	(50)	–	
DN 100	38	48	350	6	20.8	38.7	44.6	50	
			700	(35.7)	(50)	(50)	–	–	
	55	63		6.9	24.2	44.9	50	–	
	75	80		4.3	15	27.9	32.1	–	
100	100	2.7		9.6	17.8	20.6	–		
DN 100 PN 40	55	63	1400	(10.4)	(44.9)	(50)	–	–	
	75	80		(6.4)	(27.9)	(50)	–	–	
	100	100		(4.1)	(17.8)	(34.3)	–	–	
DN 150	95	80	700	4.3	15	27.9	32.1	–	
	145	100		2.7	9.6	17.8	20.6	–	
	205	125		1.8	6.1	11.4	13.2	–	
DN 150 PN 40	95	80	1400	(6.4)	(27.9)	(50)	–	–	
	145	100		(4.1)	(17.8)	(34.3)	–	–	
	205	125		(2.6)	(11.4)	(21.9)	–	–	
DN 200 und DN 250	155	100	1400	(4.1)	(17.8)	(34.3)	(39.8)	(50)	
	230	125		–	3.5	14	17.6	35.1	
	305	150		–	2.4	9.8	12.2	24.4	
	135...480	200	2800	–	1.4	5.5	6.9	13.7	
	230	125		(5.3)	(22.8)	(43.9)	(50)	–	
	305	150		(3.7)	(15.8)	(30.5)	(35.3)	–	
DN 200/250 PN 40	135...480	200	2x2800	(2.1)	(8.9)	(17.1)	(19.9)	–	
	230	125		(10.5)	(45.6)	–	–	–	
	305	150		(7.3)	(31.7)	–	–	–	
DN 300	135...480	200	1400	(4.1)	(17.8)	–	–	–	
	230	125		–	3.5	14	17.6	35.1	
	305	150		–	2.4	9.8	12.2	24.4	
	480	200	2800	–	1.4	5.5	6.9	13.7	
	1000	250		–	0.9	3.5	4.4	8.8	
	230	125		(5.3)	(22.8)	(43.9)	(50)	–	
	305	150		(3.7)	(15.8)	(30.5)	(35.3)	–	
	480	200		(2.1)	(8.9)	(17.1)	(19.9)	–	
1000	250	–	1.8	7	8.8	–			

Table 5 · Permissible differential pressures for Series 250 Valves with a AC-1 or AC-2 Trim
Table 5a · Valves with fail-safe position "Valve OPEN" (FA)

Bench range in bar with actuator size in cm ²				700	0.4...1.2	0.8...2.4	-	1.2...3.6	1.4...2.3	2.1...3.3	2.35...3.8	2.6...4.3
				1400	(0.8...1.2)	0.8...2.4		1.0...3.0	1.4...2.7	2.05...2.7	-	1.7...3.2
				2800 2x2800	(0.8...1.2)	(1.6...2.4)	(2.0...3.0)	(2.4...3.6)	(2.4...3.6)	(1.25...1.6)	(2.8...3.8)	(2.8...3.8)
Required supply pressure				Upper spring range value + 0.2 bar								
DN	K _{Vs}	SB	Actuator in cm ²	Δp when p ₂ = 0 bar								
DN 50 PN 16...40	35	50	700	11	21.9	-	32.9	38.4	-	-	-	
			1400	(43.9)	(87.8)	-	(109.7)	-	(112.4)	-	(134.4)	
DN 80 PN 16...40	35	50	700	11	21.9	-	32.9	38.4	57.6	64.4	71.3	
			1400	(43.9)	(87.8)	-	-	-	-	-	-	
	50	63	700	6.9	13.8	-	20.7	24.2	36.3	40.6	44.9	
			1400	(27.6)	(55.3)	-	-	-	-	-	-	
	16...70	80	700	4.3	8.6	-	12.9	15	22.5	25.2	27.9	
			1400	(17.1)	(34.3)	-	-	-	-	-	-	
DN 80 PN 63...160	35	50	700	11	21.9	-	32.9	38.4	57.6	64.4	71.3	
			1400	(43.9)	(87.8)	-	(109.7)	-	112.4	-	(134.4)	
	50	63	700	6.9	13.8	-	20.7	24.2	36.3	40.6	44.9	
			1400	(27.6)	(55.3)	-	(69.1)	-	(70.8)	-	(84.6)	
	16...70	80	700	4.3	8.6	-	12.9	15	22.5	25.2	27.9	
			1400	(17.1)	(43.3)	-	(42.8)	-	43.9	-	(52.5)	
DN 100 PN 16...40	38	50	700	11	21.9	-	32.9	38.4	57.6	64.4	71.3	
			1400	(43.9)	(87.8)	-	(109.7)	-	112.4	-	(134.4)	
	55	63	700	6.9	13.8	-	20.7	24.2	36.3	40.6	44.9	
			1400	(27.6)	(55.3)	-	(69.1)	-	70.8	-	(84.6)	
	75	80	700	4.3	8.6	-	12.9	15	22.5	25.2	27.9	
			1400	(17.1)	(34.3)	-	(42.8)	-	(43.9)	-	(52.5)	
	35...100	100	700	2.7	5.5	-	8.2	9.6	14.4	16.1	17.8	
			1400	(11)	(21.9)	-	(27.4)	-	(28.1)	-	(33.6)	
DN 100 PN 63...160	38	50	700	11	21.9	-	32.9	38.4	57.6	64.4	71.3	
			1400	(43.9)	(87.8)	-	(109.7)	-	112.4	-	(134.4)	
	55	63	700	6.9	13.8	-	20.7	24.2	36.3	40.6	44.9	
			1400	(27.6)	(55.3)	-	(69.1)	-	70.8	-	(84.6)	
	75	80	700	4.3	8.6	-	12.9	15	22.5	25.2	27.9	
			1400	(17.1)	(34.3)	-	(42.8)	-	43.9	-	(52.5)	
	35...100	100	700	2.7	5.5	-	8.2	9.6	14.4	16.1	17.8	
			1400	(11)	(21.9)	-	(27.4)	-	28.1	-	(33.6)	

Bench range in bar with actuator size in cm ²		700	0.4...1.2 (0.8...1.2)	0.8...2.4	-	1.2...3.6	1.4...2.3	2.1...3.3	2.35...3.8	2.6...4.3	
		1400		0.8...2.4 (1.6...2.4)		1.0...3.0 (2.0...3.0)	1.4...2.7	2.05...2.7	-	1.7...3.2 (2.45...3.2)	
		2800 2x2800	0.4...1.2 (0.8...1.2)	0.8...2.4 (1.6...2.4)	1.0...3.0 (2.0...3.0)	1.2...3.6 (2.4...3.6)	1.1...3.6 (2.4...3.6)	1.1...1.8 (1.25...1.6)	1.8...3.8 (2.8...3.8)	2.8...3.2 (2.8...3.8)	
Required supply pressure			Upper spring range value + 0.2 bar								
DN	K _{VS}	SB	Actuator in cm ²	Δp when p ₂ = 0 bar							
DN 150	95	80	700	4.3	8.6	-	12.9	15	22.5	25.2	27.9
			1400	(17.1)	(34.3)	-	(42.8)	-	43.9	-	(52.5)
			2800	-	-	-	-	-	120	107.1	120
	145	100	700	2.7	5.5	-	8.2	9.6	14.4	16.1	17.8
			1400	(11)	(21.9)	-	(27.4)	-	28.1	-	(33.6)
			2800	-	-	-	-	-	76.8	68.6	76.8
	205	125	1400	3.5	7	-	8.8	12.3	-	-	14.9
			2800	(14)	(28.1)	(35.1)	(42.1)	(22.8)	-	-	(49.1)
			2x2800	(28.1)	(56.2)	-	-	(45.6)	-	-	-
	85...250	150	1400	2.4	4.9	-	6.1	8.5	-	-	10.4
			2800	(9.8)	(19.5)	(24.4)	(29.3)	(15.8)	-	-	(34.1)
			2x2800	(19.5)	(39)	-	-	(31.7)	-	-	-
200	155	100	700	2.7	5.5	-	8.2	9.6	14.4	16.1	18.8
			1400	(11)	(21.9)	-	(27.4)	-	28.1	-	(33.6)
			2800	-	-	-	-	-	76.8	68.6	76.8
	230	125	1400	3.5	7	-	8.8	12.3	-	-	14.9
			2800	(14)	(28.1)	(35.1)	(42.1)	(22.8)	-	-	(49.1)
			2x2800	(28.1)	(56.2)	(70.2)	(84.2)	(45.6)	-	-	-
	3.5	150	1400	2.4	4.9	-	6.1	8.5	-	-	10.4
			2800	(9.8)	(19.5)	(24.4)	(29.3)	(15.8)	-	-	(34.1)
			2x2800	(19.5)	(39)	(48.8)	(58.5)	(31.7)	-	-	-
	135...480	200	1400	1.4	2.7	-	3.4	4.8	-	-	5.8
			2800	(5.5)	(11)	(13.7)	(16.5)	(8.9)	-	-	(19.2)
			2x2800	(11)	(21.9)	(27.4)	(32.9)	(17.8)	-	-	-
300	230	125	1400	3.5	7	-	8.8	12.3	-	-	14.9
			2800	(14)	(28.1)	(35.1)	(42.1)	(22.8)	-	-	(49.1)
			2x2800	(28.1)	(56.2)	(70.2)	(84.2)	(45.6)	-	-	-
	305	150	1400	2.4	4.9	-	6.1	8.5	-	-	10.4
			2800	(9.8)	(19.5)	(24.4)	(29.3)	(15.8)	-	-	(34.1)
			2x2800	(19.5)	(39)	(48.8)	(58.5)	(31.7)	-	-	-
	480	200	1400	1.4	2.7	-	3.4	4.8	-	-	5.8
			2800	(5.5)	(11)	(13.7)	(16.5)	(8.9)	-	-	(19.2)
			2x2800	(11)	(21.9)	(27.4)	(32.9)	(17.8)	-	-	-
	1000	250	2800	1.8	3.5	4.4	5.3	4.8	7.9	-	-
			2x2800	3.5	7	8.8	10.5	9.7	15.8	-	-

Table 5b · Series 250 Valves with fail-safe position "Valve OPEN" (FE)

Bench range in bar with actuator size in cm ²				700	0.2 ... 1.0				
				1400	0.4 ... 2.0 (0.3 ... 1.1)				
Required supply pressure				2.4	3.6	4.0	5.0	6.0	
DN	Kvs	SB	Actuator in cm ²	Δp when p ₂ = 0 bar					
DN 50 PN 16...40	35	50	700	38.4	–	–	–	–	
			1400	(71.3)	–	–	–	–	
DN 80 PN 16...40	35	50	700	38.4	71.3	82.3	–	–	
			1400	(71.3)	–	–	–	–	
	50	63	700	24.2	44.9	51.8	–	–	
			1400	(44.9)	–	–	–	–	
	16...70	80	700	15	27.9	32.1	–	–	
			1400	(27.9)	–	–	–	–	
DN 80 PN 63...160	35	50	700	38.4	71.3	82.3	109.7	137.1	
			1400	(71.3)	(137.1)	(159.1)	–	–	
	50	63	700	24.2	44.9	51.8	69.1	86.4	
			1400	(44.9)	(86.4)	(100.2)	–	–	
	16...70	80	700	15	27.9	32.1	42.8	53.6	
			1400	(27.9)	(53.6)	(62.1)	–	–	
DN 100 PN 16...40	38	50	700	38.4	71.3	82.3	109.7	137.1	
			1400	(71.3)	(137.1)	–	–	–	
	55	63	700	24.2	44.9	51.8	69.1	86.4	
			1400	(44.9)	(86.4)	–	–	–	
	75	80	700	15	27.9	32.1	42.8	53.6	
			1400	(27.9)	(53.6)	–	–	–	
35...100	100	700	9.6	17.8	20.6	27.4	34.3		
		1400	(17.8)	(34.3)	–	–	–		
DN 100 PN 63...160	38	50	700	38.4	71.3	82.3	109.7	137.1	
			1400	(71.3)	(137.1)	(159.1)	–	–	
	55	63	700	24.2	44.9	51.8	69.1	86.4	
			1400	(44.9)	(86.4)	(100.2)	–	–	
	75	80	700	15	27.9	32.1	42.8	53.6	
			1400	(27.9)	(53.6)	(62.1)	–	–	
35...100	100	700	9.6	17.8	20.6	27.4	34.3		
		1400	(17.8)	(34.3)	(39.8)	–	–		
DN 150	95	80	700	15	27.9	32.1	42.8	53.6	
			1400	(27.9)	(53.6)	(62.1)	(83.6)	(105)	
			2800	0	0	0	0	0	
	145	100	700	9.6	17.8	20.6	27.4	34.3	
			1400	(17.8)	(34.3)	(39.8)	(53.5)	(67.2)	
			2800	0	0	0	0	0	
	205	125	1400	3.5	14	17.6	26.3	35.1	
			2800	(22.8)	(43.9)	(50.9)	–	–	
			2x2800	(45.6)	–	–	–	–	
85...250	150	1400	2.4	9.8	12.2	18.3	24.4		
		2800	(15.8)	(30.5)	(35.3)	–	–		
		2x2800	(31.7)	–	–	–	–		

Bench range in bar with actuator size in cm ²				700	0.2 ... 1.0				
				1400	0.4 ... 2.0				
				2800 2x2800	(0.3 ... 1.1)				
Required supply pressure				2.4	3.6	4.0	5.0	6.0	
DN	K _{Vs}	SB	Actuator in cm ²	Δp when p ₂ = 0 bar					
DN 200	155	100	700	9.6	17.8	20.6	27.4	34.3	
			1400	(17.8)	(34.3)	(39.8)	(53.5)	(67.2)	
			2800	0	0	0	0	0	
	230	125	1400	3.5	14	17.6	26.3	35.1	
			2800	(22.8)	(43.9)	(50.9)	(68.4)	(86)	
			2x2800	(45.6)	–	–	–	–	
	305	150	1400	2.4	9.8	12.2	18.3	24.4	
			2800	(15.8)	(30.5)	(35.3)	(47.5)	(59.7)	
			2x2800	(31.7)	–	–	–	–	
	135...480	200	1400	1.4	5.5	6.9	10.3	13.7	
			2800	(8.9)	(17.1)	(19.1)	(26.7)	(33.6)	
			2x2800	(17.8)	–	–	–	–	
DN 300	230	125	1400	3.5	14	17.6	26.3	35.1	
			2800	(22.8)	(43.9)	(50.9)	(68.4)	(86)	
			2x2800	(45.6)	(87.8)	–	–	–	
	305	150	1400	2.4	9.8	12.2	18.3	24.4	
			2800	(15.8)	(30.5)	(35.3)	(47.5)	(59.7)	
			2x2800	(31.7)	(60.9)	–	–	–	
	480	200	1400	1.4	5.5	6.9	10.3	13.7	
			2800	(8.9)	(17.1)	(19.9)	(26.7)	(33.6)	
			2x2800	(17.8)	(34.3)	–	–	–	
	1000	250	2800	1.8	7	8.8	13.2	17.6	
2x2800			3.5	14	17.6	–	–		

The following details are required on ordering

AC-1 Trim with K_V/C_V acc. to Table 2

or

AC-2 Trim with K_V/C_V acc. to Table 3

Material

For tag no. ...

in order/quotation ...

Operating pressure in bar (a), bar (g) or
psi (a), psi (g)
at minimum, standard, and maximum
flow rate

Flow rate kg/h or m³/h
in standard or operating state at
minimum, standard, and maximum
flow rate

Process medium Density in kg/m³ and
temperature in °C/°F
Vapor pressure in bar

Pipe diameter DN ... or inch

Nominal pressure PN ... or ANSI Class ...

Material According to Table 1

Specifications subject to change without notice.

