

# Pneumatic Control Valve Type 3510-1 and Type 3510-7

## Micro-flow Valve Type 3510



### ANSI version

#### Application

Control valve designed for controlling small flow rates in pilot plants and technical research facilities.

**Valve sizes** G 1/4, G 3/8, G 1/2 · 1/4 NPT, 3/8 NPT, 1/2 NPT  
Rc 1/4, 3/8, 1/2 · ANSI 1/2", 3/4", 1"

**Pressure rating** ANSI Class 150 to Class 2500

**Temperatures** -200 to +450 °C · -328 to 842 °F

The pneumatic control valve consists of:

- Type 3510 Micro-flow Control Valve and a
- Type 3271-5 or optionally Type 3277-5 Actuator.

Type 3510 Micro-flow Control Valves are available either as:

- Globe valves
- Angle valves.

Their valve bodies are available with:

- G, NPT, or Rc screwed connections,
- Welding ends or flanges.

Stainless steel is used as the standard body material. However, a variety of special materials can also be used according to customer requirements.

#### Versions

##### Standard version

- For temperatures ranging from -10 to +220 °C (14 to 428 °F)
- ANSI Class 150 to 2500
- Globe valve or angle valve
- Female thread G 1/4, G 3/8, G 1/2 or 1/4 NPT, 3/8 NPT, 1/2 NPT
- Flanges ANSI 1/2", 3/4", 1", Class 150 to 2500
- Welding ends 1/2" and 1"

**Type 3510-1** (Fig. 3) · With Type 3271-5 Pneumatic Actuator, 120 cm<sup>2</sup> effective diaphragm area or Type 3271-52 Pneumatic Actuator, 60 cm<sup>2</sup> effective diaphragm area (see Data Sheet T 8310-1 EN)

**Type 3510-7** (Figs. 1 and 2) · With Type 3277-5 Pneumatic Actuator with 120 cm<sup>2</sup> effective diaphragm area, for integral positioner attachment (see Data Sheet T 8310-1 EN)

##### Other versions with

- **Insulating section** for temperatures ranging from -200 to +450 °C (-328 to 842 °F), with special material up to +650 °C (1200 °F)
- **Metal bellows seal** up to Class 600 with a sealing performance  $\leq 10^{-5} \frac{\text{mbar l}}{\text{s}}$ , higher pressure ratings on request
- **Handwheel**



Fig. 1 · Type 3510-7 Control Valve with Type 3760 Positioner

Fig. 2 · Type 3510-7 Control Valve with Type 3767 Positioner

Fig. 3 · Type 3510-1 Control Valve with Type 3271-52 Actuator

### Principle of operation

The process medium flows through the micro-flow control valve in the direction indicated by the arrow. The position of the valve plug (3) determines the cross-sectional area of flow between the seat (2) and the plug.

The plug stem (6) is connected to the actuator stem (8.1) by the stem connector (7) and sealed with an adjustable packing (4).

To comply with stricter environmental emissions requirements, the valve can be equipped with a double-walled metal bellows (10).

The anti-rotation device (13) prevents loosening of the screw connection between the valve body (1) and the bonnet (5) or the intermediate piece (9).

### Fail-safe position

Depending on the arrangement of the compression springs in the actuator (8) (see Data Sheet T 8310-1 EN for details), the control valve has two different fail-safe positions effective upon air supply failure:

#### "Actuator stem extends" (FA)

The valve is closed upon air supply failure.

#### "Actuator stem retracts" (FE)

The valve is opened upon air supply failure.

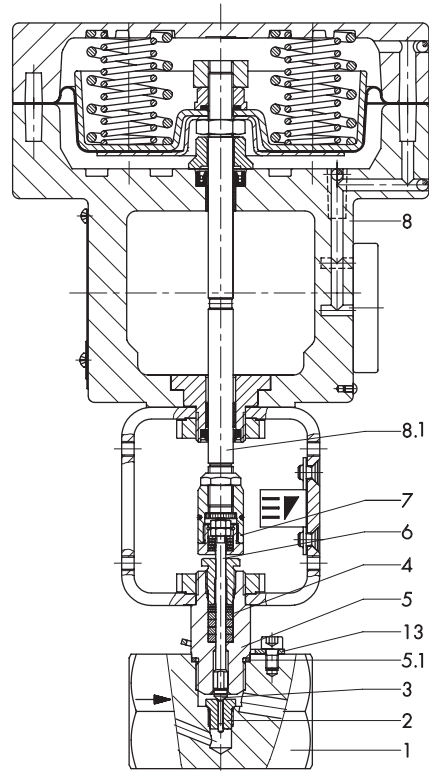

Fig. 4 · Type 3510-7 Control Valve

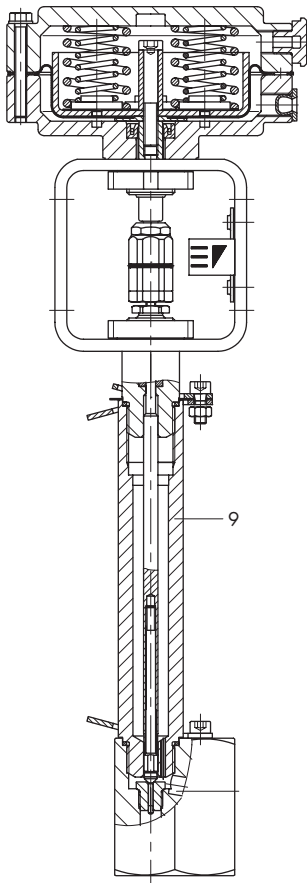

Fig. 5 · Type 3510 Valve, angle valve with insulating section and Type 3271-52 Actuator (60 cm<sup>2</sup>)

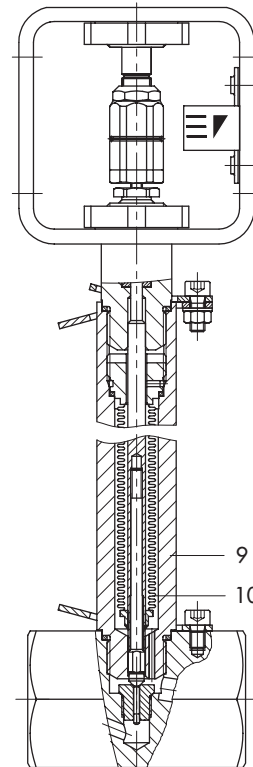

Fig. 6 · Type 3510 Valve, globe valve with metal bellows seal

**Table 1 · Technical data for Type 3510**

Connection	Female thread	Welding ends	Flanges
Valve size	G 1/4 · G 3/8 · G 1/2 1/4 NPT, 3/8 NPT, 1/2 NPT · RC 1/4, 3/8, 1/2	1/2" · 1"	1/2" · 3/4" · 1"
Pressure rating	Class 150 to 2500		
Seat/plug sealing	Metal sealing		
Characteristic	Equal percentage with $C_V \geq 0.012$ · Linear · Quick opening		
Rangeability	50 : 1 · Smaller than 50 : 1 with $C_V \leq 0.12$		
Temperature range	-10 to 200 °C · With insulating section -200 to 450 °C		
Leakage rate acc. to DIN EN 1349	With $C_V \leq 0.012$ :	Metal sealing Lapped-in metal Metal sealing Lapped-in metal	IV IV-S2 III IV

**Table 2 · Materials**

Valve body <sup>1)</sup> and bonnet <sup>2)</sup>	A 316 Ti (UNS: S31635)	2.4610 (UNS: N 06455)
Seat and plug	1.4571 / 1.4571 1.4122 / 1.4112 1.4122 / Stellite	2.4610 / 2.4610
Stuffing box packing	PTFE compound	
Body gasket	1.4571	2.4610
Insulating section	A 316 Ti	2.4610
<b>Metal bellows seal</b>		
Intermediate piece	A 316 Ti	2.4610
Metal bellows for Cl. 600 <sup>3)</sup>	1.4571	2.4819

<sup>1)</sup> Other materials available on request

<sup>2)</sup> Wetted parts

<sup>3)</sup> For higher pressure ratings on request

**Legend for Figs. 4 to 6**

- 1 Valve body
- 2 Seat
- 3 Plug
- 4 Stuffing box packing
- 5 Valve bonnet
- 5.1 Body gasket
- 6 Plug stem
- 7 Stem connector
- 8 Actuator
- 8.1 Actuator stem
- 9 Intermediate piece for insulating section  
or bellows seal
- 10 Metal bellows
- 13 Anti-rotation device

**Table 3 · Available C<sub>v</sub> coefficients**
**Table 3a · Overview**

C <sub>v</sub>		0.00012 to 0.0075 <sup>1)</sup>	0.012 to 0.3	0.5	0.75 to 2.0 <sup>2)</sup>
Rangeability		< 15 : 1	15 : 1 to 50 : 1	50 : 1	
Seat Ø	mm	2	3	4	10
Plug stem Ø	mm	4			4
Travel	mm	7.5			7.5

<sup>1)</sup> Seat and plug material in 1.4122/Stellite only

<sup>2)</sup> Only up to Class 600

**Table 3b · K<sub>vS</sub> coefficients and associated valve sizes**

Anschluss		Female thread			Welding ends		Flanges			
Flow coefficient C <sub>v</sub>	Characteristic		G 1/4 1/4 NPT Rc 1/4	G 3/8 3/8 NPT Rc 3/8	G 1/2 1/2 NPT Rc 1/2	1/2"	1"	1/2"	3/4"	1"
	Equal percentage	Linear								
0.00012	-	•	•	•	•	•	•	•	•	•
0.00020		•	•	•	•	•	•	•	•	•
0.00030		•	•	•	•	•	•	•	•	•
0.00050		•	•	•	•	•	•	•	•	•
0.00075		•	•	•	•	•	•	•	•	•
0.0012		•	•	•	•	•	•	•	•	•
0.0020		•	•	•	•	•	•	•	•	•
0.0030		•	•	•	•	•	•	•	•	•
0.0050		•	•	•	•	•	•	•	•	•
0.0075		•	•	•	•	•	•	•	•	•
0.012		•	•	•	•	•	•	•	•	•
0.020	•	•	•	•	•	•	•	•	•	
0.030	•	•	•	•	•	•	•	•	•	
0.050	•	•	•	•	•	•	•	•	•	
0.075	•	•	•	•	•	•	•	•	•	
0.12	•	•	•	•	•	•	•	•	•	
0.20	•	•	•	•	•	•	•	•	•	
0.30	•	•	•	•	•	•	•	•	•	
0.50	•	•	•	•	•	•	•	•	•	
0.75 <sup>1)</sup>	•	•	-	•	•	•	•	•	•	
1.2 <sup>1)</sup>	•	•		•	•	•	•	•	•	
2.0 <sup>1)</sup>	•	•		•	•	•	•	•	•	

<sup>1)</sup> Versions up to max. Class 600 can be used.

**Table 4 · Permissible differential pressures · Pressures in bar (gauge)**

**Table 4a · Standard version without bellows seal · Fail-safe position "Valve CLOSED"**

Bench range with actuator size		60 cm <sup>2</sup>	0.2 ... 1.0	0.4 ... 2.0	1.4 ... 2.3	2.1 ... 3.3
		120 cm <sup>2</sup>	0.4 ... 0.8	0.8 ... 1.6	1.7 ... 2.1	2.4 ... 3.1
Valve size	C <sub>v</sub>	Actuator	Δp when p <sub>2</sub> = 0 bar			
½", ¾", 1" G ¼ · G ⅜ · G ½ NPT/Rc ¼, ⅜, ½	0.00012 to 0.5	60 cm <sup>2</sup>	25	100	400	–
		120 cm <sup>2</sup>	250	400	–	–
¾", 1" G ½ NPT/Rc ½	0.75 to 2.0 <sup>1)</sup>	60 cm <sup>2</sup>	–	11	72	100
		120 cm <sup>2</sup>	35	84	100	–

<sup>1)</sup> Only up to Class 600

**Table 4b · Version with bellows seal · Fail-safe position "Valve CLOSED"**

Bench range with actuator size		60 cm <sup>2</sup>	0.2 ... 1.0	0.4 ... 2.0	1.4 ... 2.3	2.1 ... 3.3
		120 cm <sup>2</sup>	0.4 ... 0.8	0.8 ... 1.6	1.7 ... 2.1	2.4 ... 3.1
Valve size	C <sub>v</sub>	Actuator	Δp when p <sub>2</sub> = 0 bar			
½", ¾", 1" G ¼ · G ⅜ · G ½ NPT/Rc ¼, ⅜, ½	0.00012 to 0.5	60 cm <sup>2</sup>	–	10	61	95
		120 cm <sup>2</sup>	30	72	100	–
¾", 1" G ½ NPT/Rc ½	0.75 to 2.0 <sup>1)</sup>	60 cm <sup>2</sup>	–	5	55	90
		120 cm <sup>2</sup>	25	68	100	–

<sup>1)</sup> Only up to Class 600

**Table 4c · Standard version without bellows seal · Fail-safe position "Valve OPEN"**

Bench range with actuator size		60 cm <sup>2</sup>	0.2 ... 1.0		
		120 cm <sup>2</sup>	0.4 ... 0.8		
		Supply pressure	1.2	2.5	3.5
Valve size	C <sub>v</sub>	Actuator	Δp when p <sub>2</sub> = 0 bar		
½", ¾", 1" G ¼ · G ⅜ · G ½ NPT/Rc ¼, ⅜, ½	0.00012 to 0.5	60 cm <sup>2</sup>	24	400	–
		120 cm <sup>2</sup>	254	400	–
¾", 1" G ½ NPT/Rc ½	0.75 to 2.0 <sup>1)</sup>	60 cm <sup>2</sup>	–	79	100
		120 cm <sup>2</sup>	36	100	–

<sup>1)</sup> Only up to Class 600

**Table 4d · Version with bellows seal · Fail-safe position "Valve OPEN"**

Bench range with actuator size		60 cm <sup>2</sup>	0.2 ... 1.0		
		120 cm <sup>2</sup>	0.4 ... 0.8		
		Supply pressure	1.2	2.5	3.5
Valve size	C <sub>v</sub>	Actuator	Δp when p <sub>2</sub> = 0 bar		
½", ¾", 1" G ¼ · G ⅜ · G ½ NPT/Rc ¼, ⅜, ½	0.00012 to 0.5	60 cm <sup>2</sup>	–	63	100
		120 cm <sup>2</sup>	27	100	–
¾", 1" G ½ NPT/Rc ½	0.75 to 2.0 <sup>1)</sup>	60 cm <sup>2</sup>	–	63	100
		120 cm <sup>2</sup>	27	100	–

<sup>1)</sup> Only up to Class 600

**Table 5 · Permissible differential pressures · Pressures in psi (gauge)**

**Table 5a · Standard version without bellows seal · Fail-safe position "Valve CLOSED"**

Bench range with actuator size		60 cm <sup>2</sup>	3 ... 15	6 ... 30	20 ... 34	40 ... 48
		120 cm <sup>2</sup>	6 ... 12	12 ... 23	25 ... 30	35 ... 45
Valve size	Cv	Actuator	Δp when p <sub>2</sub> = 0 psi			
1/2", 3/4", 1" G 1/4 · G 3/8 · G 1/2 NPT/Rc 1/4, 3/8, 1/2	0.00012 to 0.5	60 cm <sup>2</sup>	367	1470	5880	–
		120 cm <sup>2</sup>	3675	5880	–	–
3/4", 1" G 1/2 NPT/Rc 1/2	0.75 to 2.0 <sup>1)</sup>	60 cm <sup>2</sup>	–	160	1060	1470
		120 cm <sup>2</sup>	515	1235	1470	–

<sup>1)</sup> Only up to Class 600

**Table 5b · Version with bellows seal · Fail-safe position "Valve CLOSED"**

Bench range with actuator size		60 cm <sup>2</sup>	3 ... 15	6 ... 30	20 ... 34	40 ... 48
		120 cm <sup>2</sup>	6 ... 12	12 ... 23	25 ... 30	35 ... 45
Valve size	Cv	Actuator	Δp when p <sub>2</sub> = 0 psi			
1/2", 3/4", 1" G 1/4 · G 3/8 · G 1/2 NPT/Rc 1/4, 3/8, 1/2	0.00012 to 0.5	60 cm <sup>2</sup>	–	145	900	1395
		120 cm <sup>2</sup>	440	1060	1470	–
3/4", 1" G 1/2 NPT/Rc 1/2	0.75 to 2.0 <sup>1)</sup>	60 cm <sup>2</sup>	–	75	805	1325
		120 cm <sup>2</sup>	365	1000	1470	–

<sup>1)</sup> Only up to Class 600

**Table 5c · Standard version without bellows seal · Fail-safe position "Valve OPEN"**

Bench range with actuator size		60 cm <sup>2</sup>	3 ... 15		
		120 cm <sup>2</sup>	6 ... 12		
		Supply pressure	18	36	51
Valve size	Cv	Actuator	Δp when p <sub>2</sub> = 0 psi		
1/2", 3/4", 1" G 1/4 · G 3/8 · G 1/2 NPT/Rc 1/4, 3/8, 1/2	0.00012 to 0.5	60 cm <sup>2</sup>	350	5880	–
		120 cm <sup>2</sup>	3735	5880	–
3/4", 1" G 1/2 NPT/Rc 1/2	0.75 to 2.0 <sup>1)</sup>	60 cm <sup>2</sup>	–	1160	1470
		120 cm <sup>2</sup>	530	1470	–

<sup>1)</sup> Only up to Class 600

**Table 5d · Version with bellows seal · Fail-safe position "Valve OPEN"**

Bench range with actuator size		60 cm <sup>2</sup>	3 ... 15		
		120 cm <sup>2</sup>	6 ... 12		
		Supply pressure	18	36	51
Valve size	Cv	Actuator	Δp when p <sub>2</sub> = 0 psi		
1/2", 3/4", 1" G 1/4 · G 3/8 · G 1/2 NPT/Rc 1/4, 3/8, 1/2	0.00012 to 0.5	60 cm <sup>2</sup>	–	925	1470
		120 cm <sup>2</sup>	395	1470	–
3/4", 1" G 1/2 NPT/Rc 1/2	0.75 to 2.0 <sup>1)</sup>	60 cm <sup>2</sup>	–	925	1470
		120 cm <sup>2</sup>	395	1470	–

<sup>1)</sup> Only up to Class 600

**Table 6 · Dimensions**

Valve		Connection		Female thread G/NPT/Rc 1/4", 3/8", 1/2"	Welding ends 1/2", 1"	Flanges		
						1/2"	3/4"	1"
L	Class 150	mm	74 mm 2.91"	80 mm 3.12"	184	184	184	
		in			7.25"	7.25"	7.25"	
	Class 300	mm			190	194	197	
		in			7.50"	7.62"	7.75"	
	Class 600	mm			203	206	210	
		in			8.0"	8.12"	8.25"	
	Class 900/1500	mm			216	229	254	
in		8.50"	9.0"	10.0"				
Class 2500	mm	264	273	308				
	in	10.38"	10.75"	12.12"				
H1	60/120 cm <sup>2</sup>		122 mm / 4.80"					
H4 with insulating section or bellows seal			263 mm / 10.35"					
H2 or Flange Ø D1	Class 150	mm	23 mm 0.90"	23mm 0.90"	90	100	108	
		in			3.54"	3.94"	4.25"	
	Class 300	mm			96	118	124	
		in			3.78"	4.65"	4.88"	
	Class 600	mm			96	118	124	
		in			3.78"	4.65"	4.88"	
	Class 900/1500	mm			122	132	150	
in		4.80"	5.20"	5.91"				
Class 2500	mm	134	140	158				
	in	5.28"	5.51"	6.22"				
H3	60/120 cm <sup>2</sup>		150 mm / 5.90"					
L1	Class 150	mm	34 mm 1.33"	40 mm 1.57"	92	92	92	
		in			3.62	3.62	3.62	
	Class 300	mm			95	97	98	
		in			3.74	3.82	3.86	
	Class 600	mm			101	103	105	
		in			3.98	4.06	4.13	
	Class 900/1500	mm			108	114	127	
in		4.25	4.5	5.0				
Class 2500	mm	132	137	154				
	in	5.20	5.39	6.06				
H4 with insulating section or bellows seal Class 600			140 mm / 5.51"					

Actuator	60 cm <sup>2</sup>	120 cm <sup>2</sup>
Diaphragm Ø D	120 mm / 4.72"	168 mm / 6.6"
H	63 mm / 2.48"	69 mm / 2.71"
H3	150 mm / 5.90"	150 mm / 5.90"
Thread	M20 x 1.5	M20 x 1.5
Loading pressure connection	G 1/8 or 1/8 NPT	G 1/8 or 1/8 NPT

**Table 7 · Weights**

Valve	Connection		Female thread G/NPT/Rc 1/4", 3/8", 1/2"	Welding ends 1/2", 1"	Flanges		
					1/2"	3/4"	1"
Valve without actuator	Class 150	kg/lbs	1.7/3.74	1.6/3.53	2.6/5.8	3.3/7.3	3.7/8.2
	Class 300	kg/lbs			3.2/7.1	4.2/9.3	4.8/10.6
	Class 600	kg/lbs			3.4/7.5	4.8/10.6	5.2/11.5
	Class 900/1500	kg/lbs			5.2/14.4	7.6/16.8	8.7/19.2
	Class 2500	kg/lbs			6.5/14.4	9.0/20	9.8/21.7
Optional	Insulating section	kg/lbs	0.5 / 1.2				
	Bellows seal	kg/lbs	0.6 / 1.4				

Actuator	60 cm <sup>2</sup>	120 cm <sup>2</sup>
Approx. kg/lbs	1.3 / 2.9	3.5 / 7.8

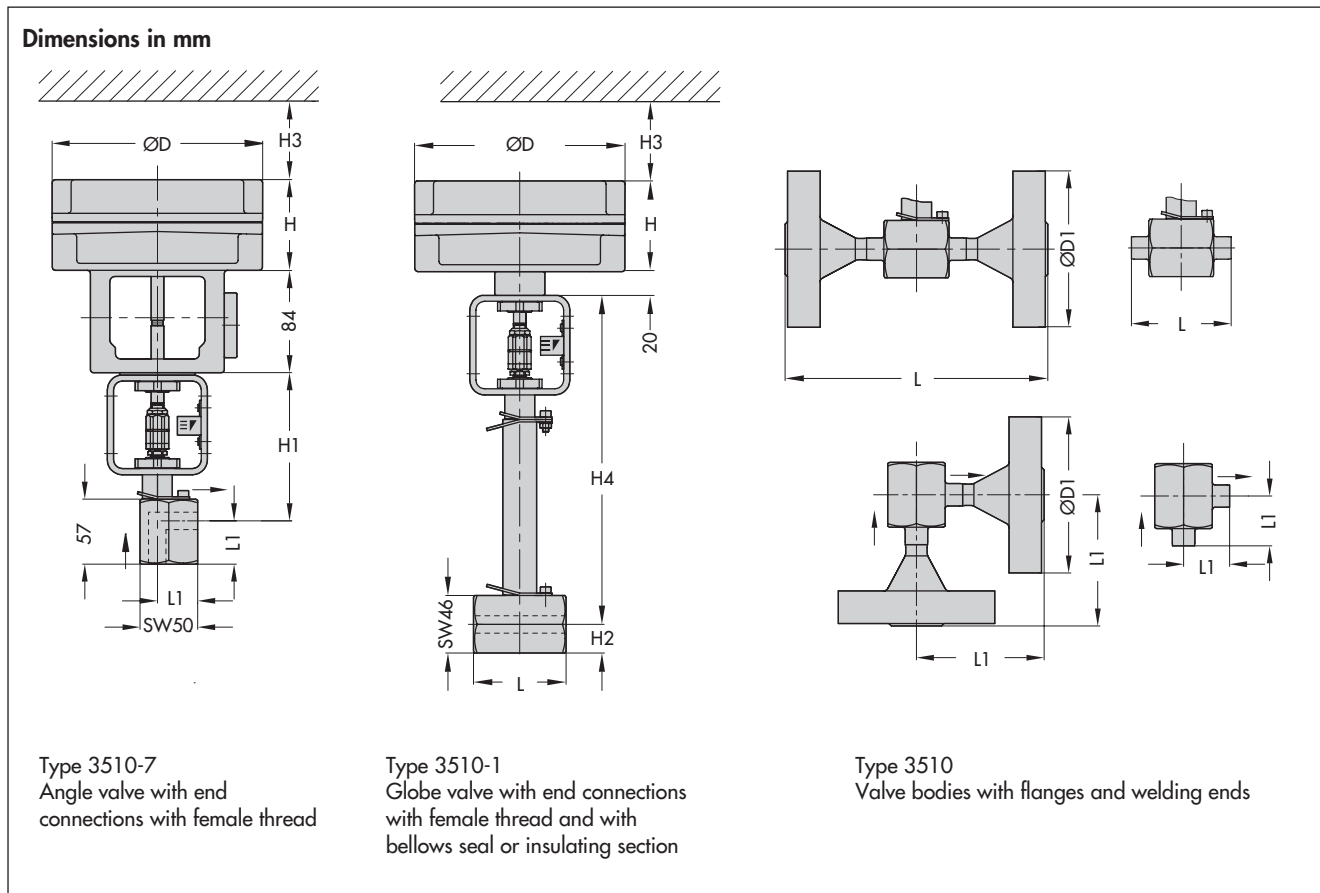

**Ordering text**

Micro-flow Valve Type 3510 Globe or angle valve in ANSI version

Valve size ... in

Pressure rating Class ...

Body material Acc. to Table 2

End connections Female thread G, NPT, Rc, flanges or welding ends

Direction of flow FTO or FTC

Characteristic Equal percentage, linear, quick opening

Pneumatic actuator Type 3271-5/Type 3277-5  
60 or 120 cm<sup>2</sup> (T 8310-1 EN)

Fail-safe position Valve CLOSED or valve OPEN

Process medium ...

Density ... kg/m<sup>3</sup>

Maximum flow rate ... kg/h or m<sup>3</sup>/h in standard or operating conditions

Pressure p<sub>1</sub> and p<sub>2</sub> in bar/psi (absolute pressure)

Medium temperature °C or K

Accessories Positioner and/or limit switch

Specifications subject to change without notice.

