

Pneumatic Control Valve Type 255-1 Globe Valve with Multi-stage Axial Plug

Type 255

Application

Control valve for low-noise and low-wear service for high industrial requirements

Nominal size DN 50 to 400
Nominal pressure PN 16 to 160
Temperatures -200 to 500 °C



Type 255 Globe Valve operated by a:

- Type 3271 Pneumatic Actuator as Type 255-1 Control Valve.

Valve body optionally made of:

- Cast steel
- Stainless cast steel
- High-temperature or cold-resisting steel.

Low-noise, three or five-stage valve plug to gradually reduce the pressure drop across the valve. Valve plug optionally with:

- Metal sealing
- Lapped-in metal
- Balanced for handling high differential pressures
- Additional stem guide in the lower body flange.

The control valves, designed according to the modular assembly principle, can be equipped with various accessories:

Positioners, limit switches, solenoid valves and other equipment according to DIN EN 60 534 and NAMUR recommendation (see Information Sheet T 8350 EN for details).

Versions

Standard version with PTFE packing for temperatures from -10 to 220 °C or with adjustable high-temperature (HT) packing for temperatures from -10 to 350 °C, nominal size DN 50 to DN 400, nominal pressure PN 16 to PN 160

- **Type 255-1** (Fig. 1) · Type 255 Valve and Type 3271 Actuator with 700 to 2800 cm² effective area (see T 8310 EN)

Further versions with

- **Nominal pressure > PN 160 to 400** · On request
- **Welding ends or welding neck ends** acc. to DIN EN 12 627
- **Flow divider** · For noise level reduction
- **Insulating section or bellows seal** · See Technical Data
- **Ceramic seat and plug** · For maximum resistance to erosion and abrasive wear, see Data Sheet T 8071 EN
- **Additional handwheel** · See Data Sheet T 8310 EN
- **Version in accordance with US standards** · Sizes 2" to 16", ANSI Class 300 to 2500, details on request.



Fig. 1 · Type 255-1 Pneumatic Control Valve with a three-stage axial plug

Principle of operation (Figs. 2 and 3)

The process medium flows through the valve in the direction indicated by the arrow. The position of the 3-stage or 5-stage valve plug determines the free area between the valve seats and plugs.

The pressure drop occurs in stages so that critical operating conditions like cavitation, excessive wear and inadmissible noise emissions are avoided.

The additional stem guide is located in the lower body flange.

A pressure-balanced valve version can be used when high pressures or differential pressures act on the valve plugs and the force produced by the actuator is insufficient.

The control valves can be equipped with a multiple flow divider to further reduce the noise level.

Fail-safe action

Depending on how the compression springs are arranged in the actuator (see details in Data Sheet T 8310 EN), the control valve has two fail-safe actions effective upon air supply failure.

"Actuator stem extends" (fail-close):

Whenever the air supply fails, the valve closes.

"Actuator stem retracts" (fail-open):

Whenever the air supply fails, the valve opens.

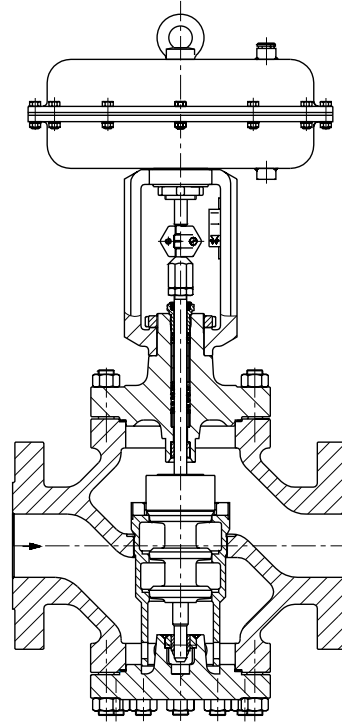

Fig. 2 · Type 255-1 Pneumatic Control Valve with a three-stage axial plug

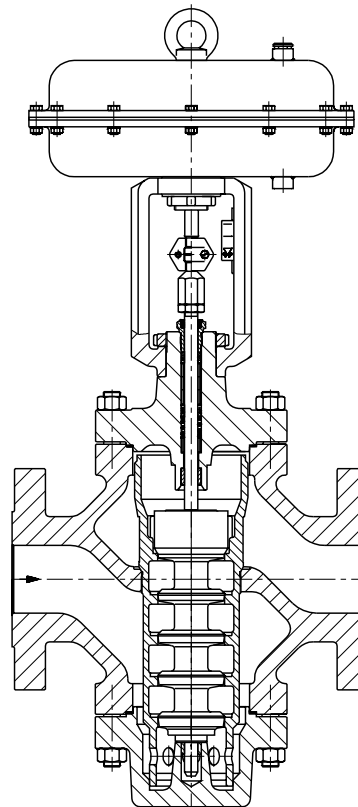

Fig. 3 · Type 255-1 Pneumatic Control Valve with a five-stage axial plug

Table 1 · Technical Data for Type 255 Globe Valve

Material		Cast steel · GS-C25 WN 1.0619	Cast steel · GS 17 CrMo 55 WN 1.7357	Stainless cast steel WN 1.4581
Nominal size ¹⁾	DN	50 ... 400		
Nominal pressure	PN	16 ... 160 ¹⁾		
End connection	Flanges	All DIN versions		
	Welding ends	According to DIN 3239 T1 with welding edge form acc. to DIN 2559		
Seat/plug sealing		Metal sealing		
Characteristic		Equal percentage or linear		
Rangeability		30 : 1		
Temperature ranges in °C · Permissible operating pressures according to pressure-temperature diagrams (see Information Sheet T 8000-2 EN)				
Valve body without insulating section		-10 ... 220 · Up to 350 °C with HT packing		
Valve plug with	Insulating section	-10 ... 400	-10 ... 500	-10 ... 450
	Bellows section	-10 ... 400	-10 ... 500	-10 ... 450
Valve plug ²⁾	Standard	Metal sealing		
	Balanced	PTFE ring		
		Graphite ring		
Leakage rate Class according to DIN EN 60 534				
Valve plug	Standard	Metal sealing		
		Lapped-in metal		
	Balanced	Metal sealing		
		IV		
		IV-S2 · DN 100 and upward: IV-S1		
		With PTFE ring: IV · With graphite ring: III		

¹⁾ Up to PN 400, details on request

²⁾ Only when appropriate body material is used.

Table 2 · Materials (WN = Material Number according to DIN)

Standard version Body and flange ¹⁾		Cast steel · GS-C25 WN 1.0619	Cast steel · GS 17 CrMo 55 WN 1.7357	Stainless cast steel WN 1.4581
Seat and plug ²⁾	Metal sealing	WN 1.4006/1.4008		WN 1.4571/1.4581
	Sealing ring for	Balanced		
		PTFE with carbon · Graphite		
Guide bushings		WN 1.4112	Hastelloy	
Stuffing box packing		V-ring packing PTFE with carbon, spring WN 1.4310 or HT packing		
Body gasket		Metal		
Insulating section		13 CrMo 44		WN 1.4571
Metal bellows seal				
Intermediate piece		13 CrMo 44		WN 1.4571
Metal bellows		WN 1.4571		

¹⁾ See also pressure-temperature diagrams (T 8000-2 EN).

Materials for temperatures above 500 °C: GS-12 CrMo 910 (WN 1.7380);
for cryogenic service GS-21 Mn 5 (WN 1.1138) or G-X6 CrNi 189 (WN 1.4308).

²⁾ All seats and valve plugs with metal sealing also with Stellite facing or plugs of pure Stellite.

Correlation between nominal size and K_{vs} value · For liquids

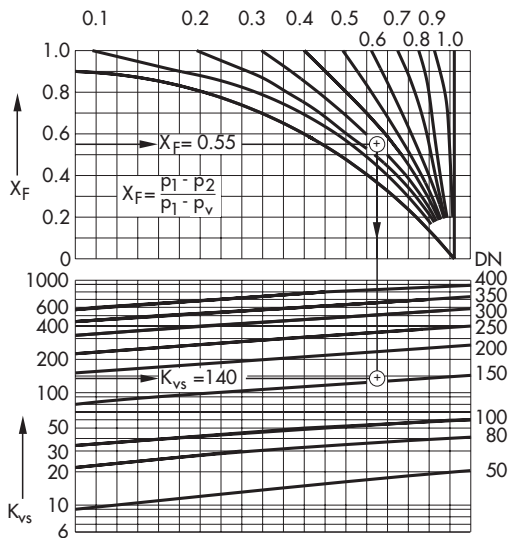

Diagram 1 · Version with 3-stage axial plug

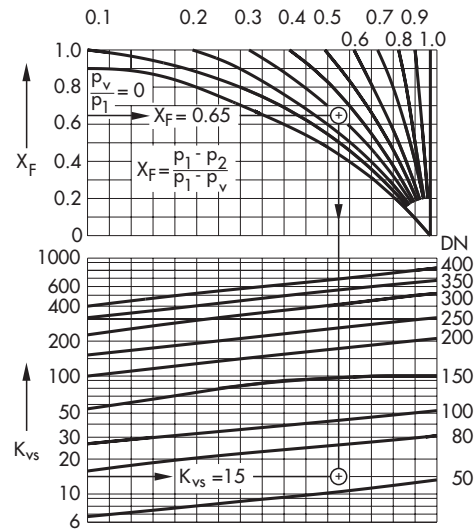
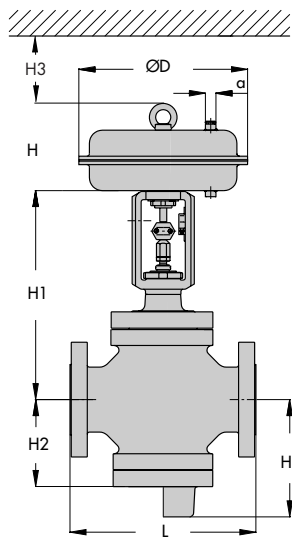
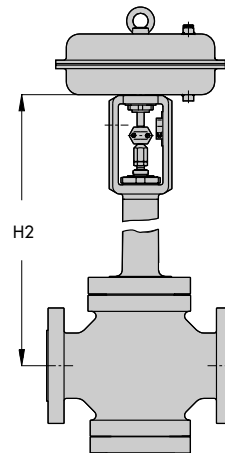

Diagram 2 · Version with 5-stage axial plug

Dimensions for Type 255-1 Pneumatic Control Valve



Type 255-1; Lower body flange: left, 3-stage; right, 5-stage



Type 255-1 with bellows or insulating section

Selection and sizing of the control valve

Control valves with multi-stage axial plugs should be carefully sized. Therefore SAMSON undertakes the sizing of the Type 255-1 Control Valves.

The following tables and diagrams only serve for the initial selection of the control valve.

1. Calculate the K_v value according to DIN EN 60 534.
2. Select the nominal size and K_{vs} value according to Diagrams 1 or 2.

3. Select an appropriate actuator.
The permissible differential pressures are available on request.
4. Select the valve body according to Tables 1 and 2 and the pressure-temperature diagrams in the Information Sheet T 8000-2 EN.

Table 3 · Dimensions in mm for Type 255-1 Pneumatic Control Valve in standard version

Valve	DN	50	80	100	150	200	250	300	400
Length L	PN 10... 40	230	310	350	480	600	730	850	1100
	PN 63...160	300	380	430	550	650	775	900	1150
H1 for actuator	700 cm ²	460		480	735	805	–		
	1400 cm ²	515		535	735	805	860	1290	–
	2800 cm ²	–			990	1060	1115	1290	
H2 for plug	3-stage	180	190	240	320	390	410	480	560
	5-stage	220	255	285	420	On request			

Type 3271 Actuator	cm ²	700	1400	2800	2 x 2800
Diaphragm Ø D		390	530	770	
H incl. lifting ring		200	287	620	1130
H3 ¹⁾		190	610	648	
Thread		M 30 x 1.5		M 60 x 1.5	
α		G 3/8 (NPT 3/8)		G 3/4 (NPT 3/4)	
				M 100 x 2	
				G 1 (NPT 1)	

¹⁾ Minimum clearance for actuator disassembly

Table 4 · Weights for Type 255-1 Pneumatic Control Valve in standard version

Valve	DN	50	80	100	150	200	250	300	400
Valve without actuator (apprx. kg)	PN 16... 40	45	80	109	255	350	620	1000	1800
	PN 63...160	85	120	155	350	800	1350	2000	On request

Actuator	cm ²	700	1400	2800	2 x 2800
Type 3271 (approx. kg) ¹⁾	Without	22	70	450	950
	With handwheel	27	Only with side-mounted handwheel, see T 8310 EN		

¹⁾ Top row without handwheel, bottom row with handwheel

Table 5 · Dimensions and weights for Type 255-1 Pneum. Control Valve in standard version with insulating section · Without actuator

Nominal size	DN	50	80	100	150	200	250	300	400
Height H4 for actuator	700 cm ²	740		760	1085	–			
	1400 cm ²	795		815	1085	1365	1485	1810	–
	2800 cm ²	–			1340	1620	1740	1810	1870
Weight (kg) without actuator for	PN 16 ... 40	55	90	119	265	600	700	1400	2200
	PN 63 ...160	95	130	165	365	900	1500	2200	On request

Table 6 · Dimensions and weights for Type 255-1 Pneum. Control Valve in standard version with metal bellows · Without actuator

Nominal size	DN	50	80	100	150	200	250	300	400
Height H4 for actuator	700 cm ²	680		705	1085	1190	–		
	1400 cm ²	735		760	1140	1190	1320	1640	–
	2800 cm ²	–			1400	1450	1570	1640	1720
Weight (kg) without actuator for	PN 16 ... 40	55	90	119	265	600	700	1400	2200
	PN 63 ...160	95	130	165	365	900	On request		

The following details are required on ordering

Nominal size/pressure	DN ... /PN ...
Body material	According to Table 2
End connection	Flanges/welding ends
Plug	3-stage/5-stage, Standard/balanced, Metal sealing or lapped-in metal
Characteristic	Equal percentage or linear
Actuator	Type 3271 (see T 8310 EN)
Fail-safe action	Valve closes or valve opens
Process medium	Density in kg/m ³ and temperature in °C
Flow rate	kg/h or m ³ /h in standard and operating condition
Pressure	p ₁ and p ₂ in bar (absolute pressure p _{abs}), both with minimum, standard and maximum flow
Accessories	Positioner and/or limit switches

Specifications subject to change without notice.

