

NR	ANDRINC	DATUM	ANDR	GOODK
1	Pos. 11/12 and 18 was changed.	001024	CE	
2	D/P3/5 var P3	030123	LTO	

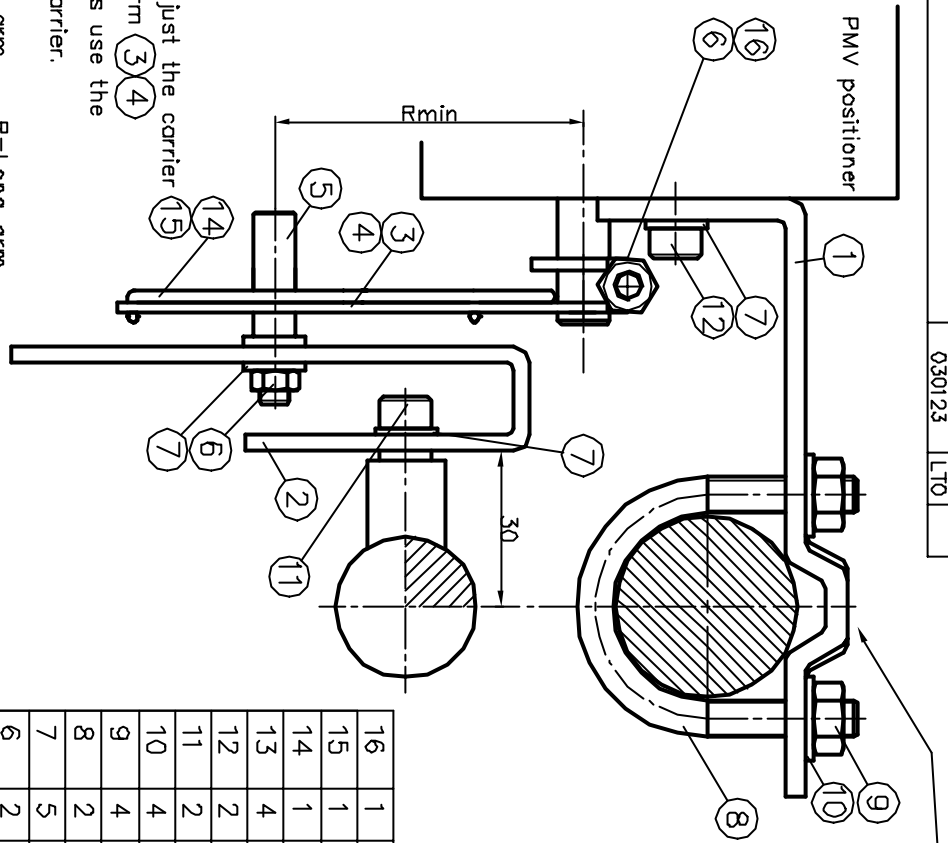

For P3-positioner series, adjust the carrier (3) (4) due to the marks on the arm (3) (4)  
 For all other PMV positioners use the table below to adjust the carrier.

S=cylinderstroke    A=Short arm    B=Long arm

S	30°	Adjustments Rmin	45°	60°	90°
10	18,7 - A	19,3 - A	-	-	-
16	29,9 - A	24,1 - A	-	-	-
20	37,3 - A	36,2 - A	-	-	-
30	56,0 - A	38,6 - A	27,7 - A	-	-
32	59,7 - A	60,4 - A	43,3 - A	25,0 - A	-
50	93,3 - B	66,4 - A	47,6 - A	27,5 - A	-
55	102,6 - B	78,5 - B	56,3 - A	32,5 - A	-
65	121,3 - B	90,5 - B	65,0 - A	37,5 - A	-
75	140,0 - B	96,6 - B	69,3 - A	40,0 - A	-
80	-	120,7 - B	86,6 - B	50,0 - A	-
100	-	126,7 - B	90,9 - B	52,5 - A	-
105	-	-	103,9 - B	60,0 - A	-
120	-	-	-	100,0 - B	-
200	-	-	-	-	-

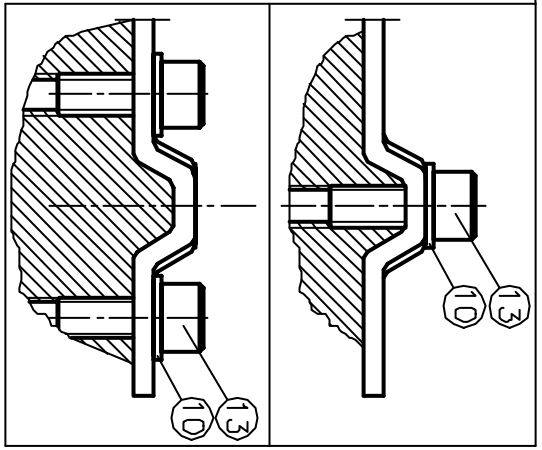

16	1	Screw		M6S 6x25 A2/A4
15	1	Holder, long	P3-67	
14	1	Holder, short	P3-68	
13	4	Screw		MC6S 8x20 A2/A4
12	2	Screw		MC6S 6x12 A2/A4
11	2	Screw		MC6S 6x10 A2/A4
10	4	Washer		FBB 8,2 DIN 127 A2/A4
9	4	Nut		M6M 8 A2/A4
8	2	U-bolt		M8-43-45,5 A2/A4
7	5	Washer		FBB 6,1 DIN 127 A2/A4
6	2	Nut		M6M 6 A2/A4
5	1	Carrier	28201	
4	1	Arm, long, B	P3-66	
3	1	Arm, short, A	P3-65	
2	1	Bracket	28200	
1	1	Bracket	28204	

DET.NR	AMT.	BENYAKINING	MATERIAL	DIMENSION	ANM.
HAL.TOL.		EJ URSATTA TOLERANSER ENL.	YTA	PROJEKTION ELLIPSA	
<b>PMV mountingkit for D/P3/5</b>					
PALMSTERNAS INSTRUMENT AB KORTA GATAN 9 SE-171 94 SOLNA - TEL: +46 (0)8 555 106 00 FAX: +46 (0)8 555 106 01					
			IEC 534-6		
RITAD TGL		GOODK SKALA		DATUM 000529	
<b>29414</b>					