

XL Actuator Range

Full Product Range & Technical Specifications



- *High quality and economical actuator*
- *Improve plant and operator safety*
- *Reliable and flexible in process control*
- *Increase serviceability*

HYTORK 

EMERSON[™]
Process Management



XL Actuators

Complete solutions from HYTORK

***The highest quality,
most economical
actuator anywhere!***

***This unique combination
of high quality, modular
actuator design,
unique features,
customer benefits and
economical cost has
been achieved by
substantial engineering
and financial investment
by HYTORK.***

HYTORK has been manufacturing actuators for over 26 years and, through continuous improvement resulting from valuable input from our customers, has developed the XL range of actuators.

These heavy duty actuators have a proven track record of reliable operation in both industrial and commercial applications.

The XL actuator is modular in design, allowing many different functional features to be assembled from a series of modules at the factory or on site.

All XL actuators are field convertible from double acting to spring return (or vice versa).

XL spring return actuators are easily field modified to suit changing plant air and/or valve fail mode requirements.

Many of the XL actuators can have end cap modules added that provide a declutchable, manual override.

Hytork's unique On-Line Test module for ESD valves can be added to all XL spring return actuators.

All XL actuators feature the new "star" pinion drive, providing greater flexibility for direct or bracket mounting to an increased range of valve designs, including valves that have an ISO 5211 design with the stem turned at 45 degrees.

All Hytork XL actuators are manufactured to the latest international interface standards: ISO 5211, NAMUR and VDI/VDE. These standards assist efficient and accurate assembly of automated packages.



Additional Hytork XL features

- Extra mounting holes for top and bottom mounted accessories (including Hytork's direct mount interface for butterfly valves).

- Extra mounting holes near NAMUR solenoid valve pad to facilitate filter/regulator bracket installation.

- Hytork's unique direct mount interface for the most popular, non ISO 5211 designed butterfly valves.

- Stainless steel coupling inserts for direct mount ISO 5211 valves and other popular valve stems.

- Site proven DURASTRIP bearings protect all moving parts for guaranteed high cycle life.

- Change a solenoid or positioner, adjust a switch, alter a spring rating or install a new set of bearings and seals (never a spring set) in just minutes.

- A rugged, heavy duty body casting, patented SAFEKEY, unbreakable springs and HYTORK'S safety retractor bolt system for disassembly of spring return actuators.

These and other Hytork features:

- reduce capital, assembly and installation costs
- increase personnel and plant safety
- increase plant up time
- reduce maintenance costs
- extend the package life

Complete Solutions with Hytork's XL

HYTORK can supply complete customized packages tailored to suit the individual customers' needs and plant application requirements.

In addition to the many features that the XL offers, HYTORK's Complete Solutions package can also provide the following benefits:

- Full engineering and GA drawing capability in each sales office

- Standard, non-standard and special application equipment.

- A guaranteed rapid response to enquiries and orders with many items stocked locally to ensure a same day service if required.

- Short lead times facilitated by a global distribution network, backed up by a massive stock of process control equipment.

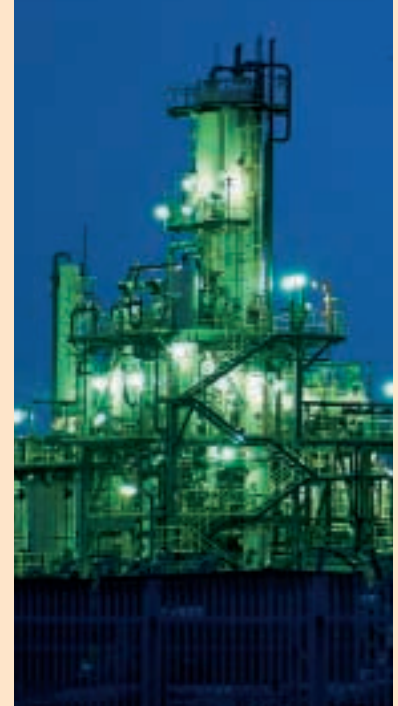



XL star drive pinions and stainless steel adapters

All Hytork XL pinion drives are manufactured to ISO 5211. Hytork's "star" drive provides additional flexibility and simplicity in valve/actuator mounting. A range of stainless steel pinion drive adapters allows many valves to be close mounted for a compact, low cost package.

The XL Commando for aggressive corrosive environments

The XL Commando is treated with Fluoropolymers from the Hytork CG range to give maximum protection against corrosive attack. Years of field

trials have proven this complete durable impregnation of all body parts (inside and out) to be the answer to many corrosive environments.

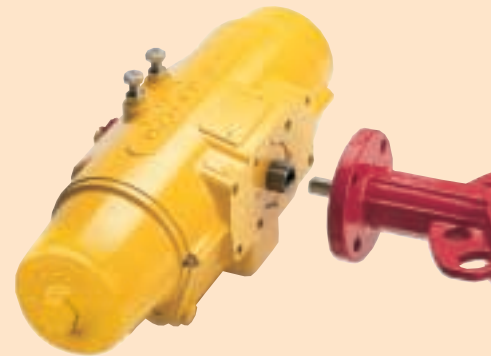

The XL manual override

A simple end cap assembly exchange provides an efficient, compact, light-weight manual override for many XL models. No modification is required to valve brackets and couplings, and torque losses are eliminated. Various handwheel designs can be fitted to suit customer requirements.



The XL On-Line Test unit

Hytork's On-Line Test module permits testing of Emergency Shut Down (ESD) and other important valves, solenoids and switches without upsetting the process.

- Each ESD unit can have its own interlocking device to ensure only that particular tag number is tested at any one time.
- ESD units can be retrofitted to existing HYTORK actuators and to any HYTORK automated quarter turn valve.
- HYTORK can also provide On-Line Test units to replace any other manufacturers' actuator and cater for individual plant requirements or special requirements for interlocking.



XL Actuators

Materials of Construction

Model Numbers	Component Description	Material	Qty
XL26–XL4580	Ball Bearing	High Carbon Chromium Steel	2
XL26–XL4580	Sealing 'O' rings	Nitrile Rubber (Optional: Viton, EPDM or Silicone)	10
XL26–XL221	Bearings (Piston & Pinion)	Acetal M90	6
XL280–XL4580	Bearings (Piston & Pinion)	MoS2 Impregnated Polymer	4
XL26–XL221	Steel Thrust Washer	Stainless Steel	1
XL280–XL4580	Steel Thrust Washer	Steel, Zinc plated	2
XL26–XL4580	Durastrip Thrust Washer	MoS2 Impregnated Polymer	1
XL26–XL4580	Circlip	Spring Steel, Zinc plated	1
XL26–XL221	Position Indicator	Nylon	1
XL280–XL4580	Position Indicator	Polypropylene	1
XL280–XL4580	Body	Aluminium, Ceramigard Treated and Two Pack Epoxy Coated	1
XL26–XL4580	SAFEKEY Head	Composite	
XL26–XL4580	SAFEKEY Wire	Stainless Steel	2
XL26–XL221	Thread Insert (Piston)	Steel, Zinc Plated	2
XL26–XL221	Location Ring	Acetal M90	1
XL26–XL4580	Pinion	Steel Cobalt Zinc Plated	1
XL26–XL4580	Piston	Aluminium	2
XL26–XL221	End Cap	Aluminium, Electrophoretic Coated and Two Pack Epoxy Coated	2
XL280–XL4580	End Cap Two Pack Epoxy Coated	Aluminium, Ceramigard Treated and 2	
XL26–XL4580	Grease	Lithium based (for Nitrile Rubber)	
XL26–XL1370	Travel Stop/Locking Nut	Stainless Steel	2
XL26–XL1370	Thread Seal	Steel, Zinc Plated/Rubber	2
XL425,680,1370,2585 & 4580	*Retractor Cap	Steel, Zinc Plated	2
XL280 & XL1125	*Retractor Cap	Aluminium	2
XL26–XL4580	*Springs	Spring Steel, Electrophoretic Coated	2 or 4

*Spring Return Models Only

Actuator specification

- Pneumatic actuators will be double rack and pinion design with bodies manufactured of cast aluminium alloy.
- All moving parts, piston racks and pinions will be fitted with replaceable wear bearings to resist cylinder side loads, radial pinion loads and up thrust/down thrust pinion loads.
- Actuators will have two rotational travel stops, acting on the rotating pinion, providing 10 degrees of travel adjustment in both directions of pinion rotation, and will have a minimum total rotational capability of 96°.
- Actuators will be designed to the preferred ISO mounting and drive dimensions, have ISO and VDI specification mounting pads for accessories with a NAMUR accessory drive on the pinion top and a NAMUR specification solenoid mounting pad.
- Actuators will have a ceramic like finish on all body parts and will be coated with a two-part epoxy paint for corrosion resistance.
- Spring return actuators will have a maximum of two springs per end cap, and will have a lifetime warranty against spring breakage.
- End caps will be securely attached to the actuator body using a flexible, stainless steel key in a machined key way.
- Suggested manufacturer and model number is HYTORK XL SR series for spring return and HYTORK XL DA series for double acting.

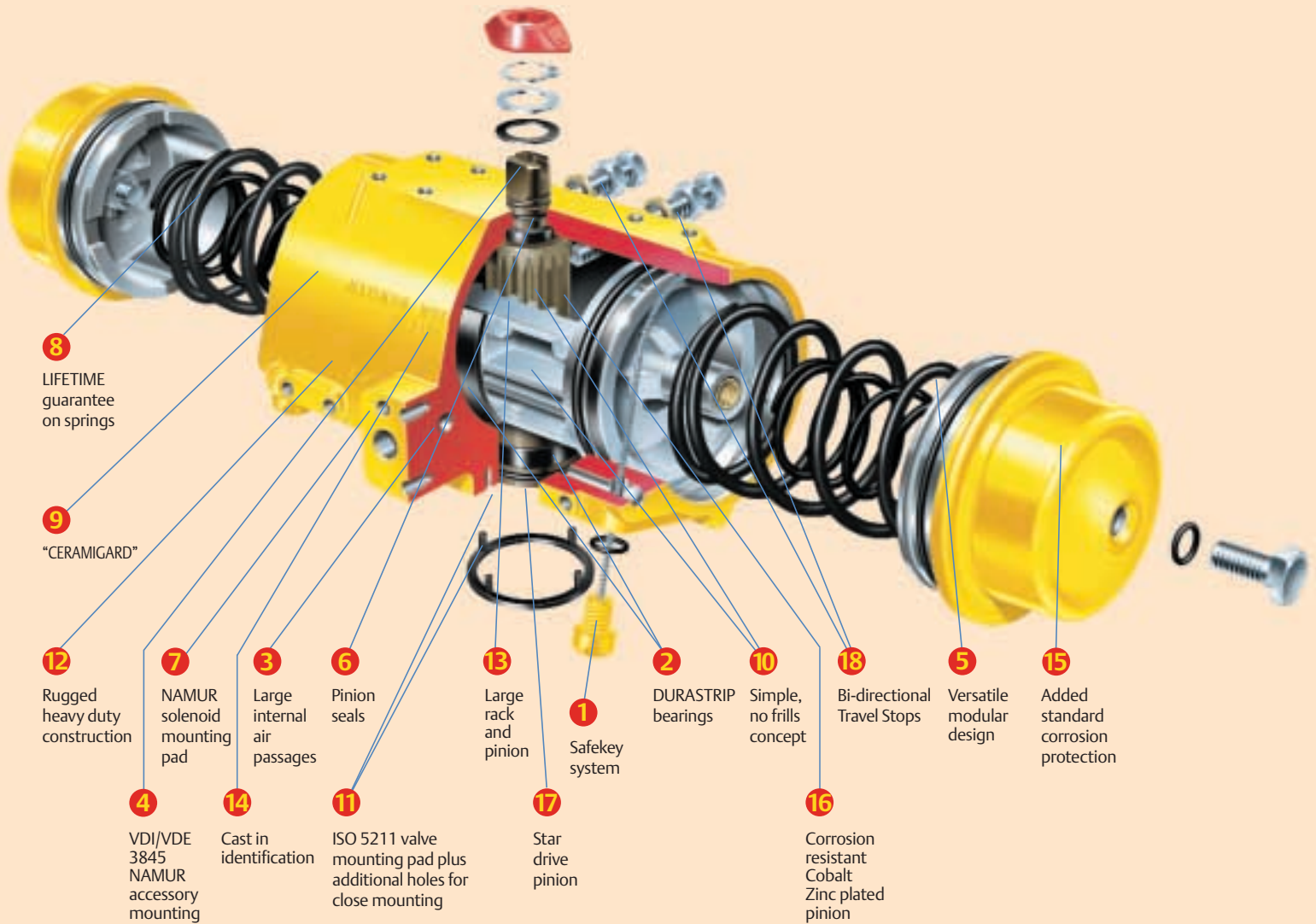

XL Actuator

1 Safekey system

This patented Safekey method of end cap assembly to the actuator uses a patented flexible stainless steel key in an internal machined keyway. The Safekey is completely sealed from all external contamination. Stronger than conventional bolting, more secure than Helicoils™, the Safekey system eliminates stress concentrations caused by point loading. Safekeys cannot be removed when the XL actuator is pressurized or springs are not safely contained, eliminating potentially dangerous disassembly.

2 DURASTRIP bearings

All moving parts are protected by permanently lubricated, long lasting DURASTRIP bearings that extend the actuator's life in the most severe and demanding conditions.

3 Large internal passages

HYTORK's extra large internal air passages permit maximum speed of operation and greatly reduce the possibility of the air passages blocking.

4 VDI/VDE 3845 NAMUR accessory mounting (an international standard)

This standard includes a slotted drive in the top of the pinion, providing a self centering, positive, no slop drive for top mounted accessories. All switches, positioners, etc. manufactured to the VDI/VDE standard, can be directly driven by the actuator pinion, eliminating expensive couplings. Hytork's standard visual position

indicator, snaps on to this pinion design. This “standard” mounting pad simplifies the addition of all “state-of-the-art” top mounted accessories. Using HYTORK’s engineered “SAFEMOUNT”, ANY accessory made to the VDI/VDE standard can be mounted to the actuator or one can still nipple mount a solenoid valve in the tapped hole. The choice is yours.

5 Versatile modular design
Customize the Hytork actuator to fit your needs. Hytork’s modular design permits shop or field changes in action (double acting or spring return), fail position, spring rating, manual override requirements, plus testing and locking devices.

6 Pinion seals
Pinion seals are positioned as close to the external surfaces as possible to minimise any crevices for maximum protection against corrosion.

7 NAMUR solenoid mounting pad (an international standard)
This permits a choice of various manufacturers’ solenoid valves to be direct mounted to the actuator. A single solenoid can be used for all double acting and spring return sizes. Hytork’s “CATS” direct mounted solenoid valve prevents aggressive ambient air from entering the spring chambers. In addition to the NAMUR holes many sizes of the XL actuator range are also provided with four additional holes to assist attaching brackets for filter regulators and solenoid valves that cannot be direct mounted.

8 LIFETIME guarantee on springs
Put the SAFE in Fail Safe! HYTORK’s springs are designed and manufactured never to break, and are then protected from corrosion using an electrophoretic finish. Springs are rated to compensate for “spring set” for true fail safe confidence. Hytork springs are guaranteed for life and backed by a FREE complete actuator replacement. Hytork springs can be matched for any air supply pressure and valve requirement - easily and safely.

9 “CERAMIGARD”
The body has a unique surface finish of Di-aluminium Tri-oxide (Al₂O₃); a hard, corrosion resistant ceramic like surface, protecting all body parts against wear and corrosion.

10 Simple, no frills concept
Only three moving parts; one pinion, two pistons.

11 ISO 5211 valve mounting pad (an international standard) plus additional holes for close mounting
Hytork XL actuators are all provided with ISO 5211 mounting holes. Many sizes have two ISO 5211 hole patterns plus additional holes outside the ISO pattern. These two hole patterns provide flexibility in mounting to all types and makes of quarter turn valves, whether they are ISO 5211 or not. The outer mounting holes, coupled with HYTORK’s optional, low cost mounting subplates, allow the close coupling of most makes of valves that are not ISO 5211.

12 Rugged heavy duty construction
The XL body designed as industrial grade and made from a heavy duty casting to provide maximum protection against dents, shock or fatigue.

13 Large rack and pinion for precision modulating control applications
The extra large, precision rack and pinion reduces “dead band” for accurate modulating control applications.

14 Cast in identification
Model numbers, port identifications, ratings, foundry trace and safety instructions are cast in for permanent readability. No lost identification due to weathering or paint.

15 Added standard corrosion protection
A long heat cured, two part epoxy surface treatment is standard, providing extra protection against aggressive environments.

16 Corrosion resistant Cobalt Zinc plated pinion
All Hytork actuator pinions are Cobalt Zinc plated. This durable treatment shows no signs of corrosion after over 2000 hours in a salt spray test.

17 Star drive pinions and new stainless steel adapters
All Hytork XL pinion drives are manufactured to ISO 5211. Hytork’s new star drive provides additional flexibility and simplicity in valve/actuator mounting. Optional star drive sizes are available. A range of stainless steel pinion drive adapters allows many valves to be close mounted for a compact, low cost package.

18 Bi-directional Travel Stops

XL26 - XL1370

- 1 A unique, exclusive standard provides rotational adjustment on the actuator pinion, in both directions of travel.
- 2 High performance and special duty valves require precise and specific rotation limits to perform their intended function.
- 3 Metal seated and high performance butterfly valves need exact rotation stopping between 0° and 7° .
- 4 Rubber seated butterfly valves often require stopping between 0° and 7° after installation, for optimum seat life. These valves can experience premature seat failure if the disc is forced into the seat.
- 5 Full port and metal seated ball valves need exactly 0° and 90° .
- 6 All manufactured items have acceptable tolerances. When the tolerance of the components of an automated valve assembly are added, the actuator must provide compensation by being able to rotate more than 90° with overtravel in both directions, and then continually stop precisely at the required position.

- 7 Hytork actuators, with patented two way rotation travel stops, provide a minimum rotation of -3° to $+93^{\circ}$ and positive, adjustable rotation stopping (10° at each end).
- 8 This unique Hytork combination assures positive sealing, correct port alignment and long life for all valve designs.
- 9 Single end cap stops and dual end cap stops cannot limit rotation when the actuator pistons are driven together (as in all "fail" strokes) and provide no function. Actuators without sufficient overtravel, in both directions of rotation, cannot assure correct valve functioning.
- 10 Overtravel and Rotation Travel Stops are required to compensate for the accumulation of tolerances that lead to valve malfunction and damage.

XL2585 - XL4580

On the larger sizes of Actuators the adjustment is obtained by the addition of a simple Stop Block that fits under the Actuator. The Actuator is manufactured with over travel to give -3° to $+93^{\circ}$ of movement and the bottom mounted Stop Block provides the required adjustment of 10° at each end of the travel.

Valve Open
No Travel Stops

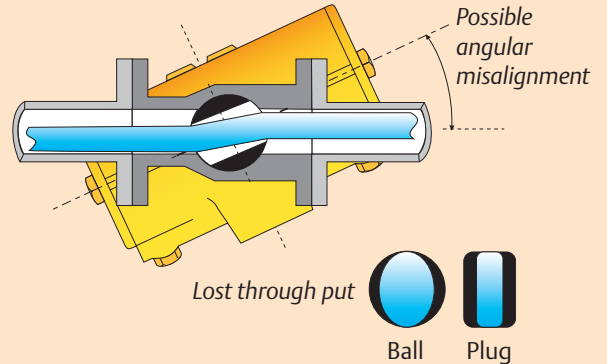

Valve Closed
No Travel Stops

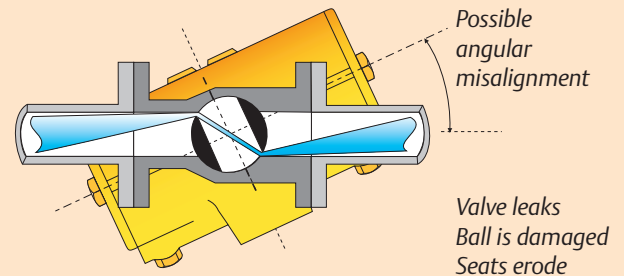

Valve Open
with Travel Stops

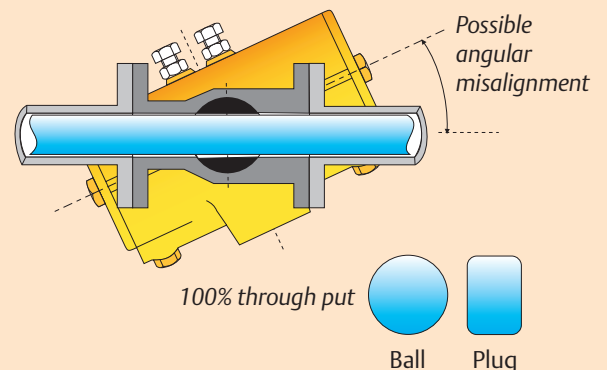

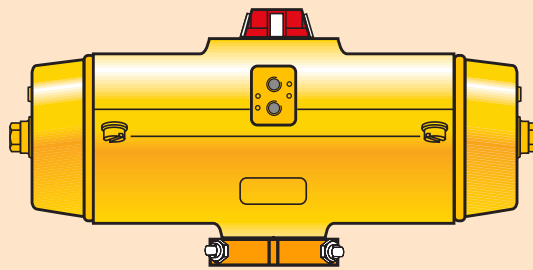
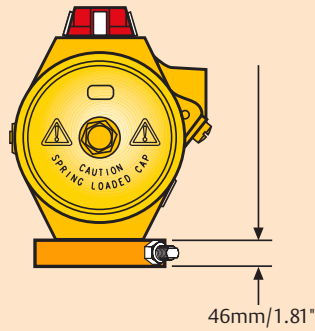
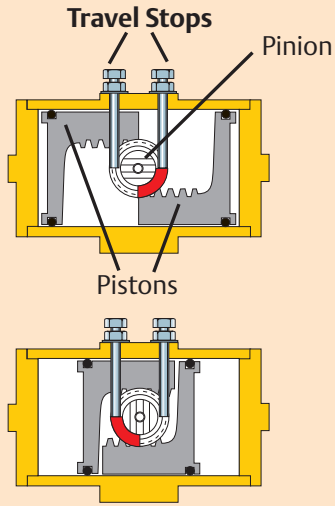

Travel adjustment

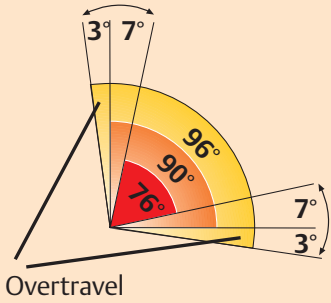

Travel adjustment

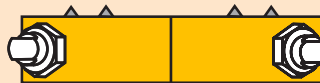
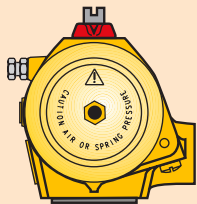
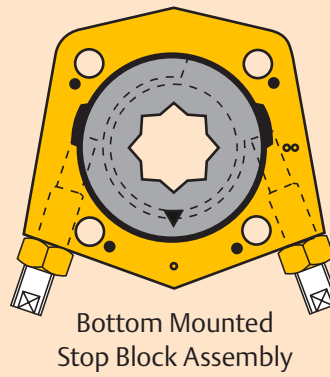
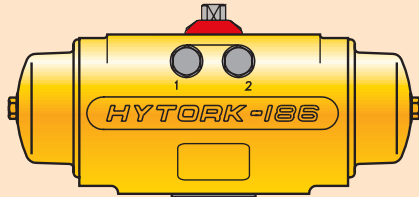

XL26 - XL1370

XL2585 - XL4580



Spring Return Actuators Torque Data (Pressures in barg and torques in Nm.)

Torques from air stroke (Nm.) @ given operating air pressure (barg)

Model	Spring Rating	Torque from Springs		3.0 barg		4.0 barg		5.0 barg		5.5 barg		6.0 barg		7.0 barg		8.0 barg		9.0 barg		10.0 barg		
		Start	End	Start	End	Start	End	Start	End	Start	End	Start	End	Start	End	Start	End	Start	End	Start	End	
XL26 SR	S4	6	4	7	4	10	8	14	11	15	13	17	15	21	18	24	22	27	25	31	28	
	S5	7	4	6	3	9	6	13	10	14	12	16	13	20	17	23	20	27	24	30	27	
	S6	9	5	5	1	8	5	12	8	14	10	15	12	19	15	22	19	26	22	29	26	
	S7	10	6	-	-	8	3	11	7	13	9	14	10	18	14	21	17	25	21	28	24	
	S8	12	7	-	-	7	2	10	5	12	7	14	9	17	12	20	16	24	19	27	23	
	S9	13	8	-	-	-	-	9	4	11	6	13	7	16	11	20	14	23	18	26	21	
	S10	15	9	-	-	-	-	8	2	10	4	12	6	15	9	19	13	22	16	26	20	
XL71 SR	S4	15	9	17	11	26	20	34	28	38	32	43	37	51	45	60	54	69	63	77	71	
	S5	19	11	15	7	23	16	32	24	36	29	41	33	49	42	58	50	66	59	75	68	
	S6	22	13	12	4	21	12	30	21	34	25	38	29	47	38	55	47	64	55	73	64	
	S7	26	16	-	-	19	8	27	17	32	21	36	26	45	34	53	43	62	51	70	60	
	S8	30	18	-	-	17	5	25	13	30	18	34	22	42	31	51	39	60	48	68	56	
	S9	33	20	-	-	-	-	23	10	27	14	32	18	40	27	49	35	57	44	66	53	
	S10	37	22	-	-	-	-	21	6	25	10	29	15	38	23	47	32	55	40	64	49	
XL131 SR	S4	28	17	32	21	48	37	64	53	72	61	80	69	97	85	113	102	129	118	145	134	
	S5	35	21	28	14	44	30	60	46	68	54	76	62	92	78	109	95	125	111	141	127	
	S6	42	25	23	7	40	23	56	39	64	47	72	55	88	71	104	88	121	104	137	120	
	S7	49	29	-	-	35	16	52	32	60	40	68	48	84	64	100	81	116	97	133	113	
	S8	56	33	-	-	31	9	47	25	56	33	64	41	80	57	96	74	112	90	128	106	
	S9	63	38	-	-	-	-	43	18	51	26	59	34	76	51	92	67	108	83	124	99	
	S10	70	42	-	-	-	-	39	11	47	19	55	27	71	44	88	60	104	76	120	92	
XL186 SR	S4	37	22	43	28	65	50	86	71	97	82	108	93	130	115	152	137	173	159	195	180	
	S5	47	28	37	19	59	40	81	62	92	73	102	84	124	106	146	127	168	149	190	171	
	S6	56	34	32	9	53	31	75	53	86	64	97	75	119	96	140	118	162	140	184	162	
	S7	65	39	-	-	48	22	70	43	80	54	91	65	113	87	135	109	157	131	178	152	
	S8	75	45	-	-	42	12	64	34	75	45	86	56	108	78	129	99	151	121	173	143	
	S9	84	50	-	-	-	-	58	25	69	36	80	46	102	68	124	90	145	112	167	134	
	S10	93	56	-	-	-	-	53	15	64	26	75	37	96	59	118	81	140	102	162	124	
XL221 SR	S4	52	31	60	39	90	69	120	99	135	114	151	130	181	160	211	190	242	221	272	251	
	S5	65	39	52	26	82	56	112	86	128	101	143	117	173	147	203	177	234	208	264	238	
	S6	78	47	44	13	74	43	105	73	120	88	135	104	165	134	196	164	226	194	256	225	
	S7	91	55	-	-	66	30	97	60	112	75	127	90	157	121	188	151	218	181	248	212	
	S8	105	63	-	-	59	17	89	47	104	62	119	77	150	108	180	138	210	168	240	199	
	S9	118	71	-	-	-	-	81	34	96	49	111	64	142	95	172	125	202	155	233	186	
	S10	131	78	-	-	-	-	73	21	88	36	104	51	134	82	164	112	194	142	225	173	
XL280 SR	S4	62	37	72	47	108	83	144	119	162	137	180	155	217	192	253	228					
	S6	93	56	53	16	89	52	125	88	144	106	162	125	198	161	234	197					
	S8	124	75	-	-	71	21	107	57	125	75	143	93	179	130	216	166					
	S10	155	93	-	-	-	-	88	26	106	44	125	62	161	99	197	135					
XL425 SR	S3	68	41	118	91	171	144	224	197	250	223	277	249	329	302	382	355					
	S4	91	54	104	68	157	121	210	174	237	200	263	227	316	280	369	333					
	S5	113	68	91	45	144	98	197	151	223	178	249	204	302	257	355	310					
	S5A	125	77	82	34	135	87	188	140	214	166	241	193	294	246	346	299					
	S6A	147	88	-	-	123	64	176	117	203	144	229	170	282	223	335	276					
	S8	181	109	-	-	103	30	156	83	182	110	209	136	262	189	314	242					
	S10	217	145	-	-	-	-	119	47	146	74	172	100	225	153	278	206					
XL680 SR	S3	111	66	192	148	278	234	365	320	408	363	451	407	537	493	623	579					
	S4	148	89	170	111	256	197	343	284	386	327	429	370	515	456	601	542					
	S5	185	111	148	74	234	160	320	247	363	290	407	333	493	419	579	505					
	S5A	203	125	134	56	220	142	306	228	349	271	392	314	479	401	565	487					
	S6A	240	144	-	-	201	105	287	191	330	234	373	277	460	364	546	450					
	S8	295	177	-	-	168	50	254	136	297	179	340	222	426	308	513	394					
	S10	354	236	-	-	-	-	195	77	238	120	281	163	367	249	454	336					
XL1125 SR	S4	247	148	285	186	429	330	573	475	646	547	718	619	862	763	1006	908					
	S6	371	222	211	62	355	207	499	351	571	423	644	495	788	640	932	784					
	S8	494	297	-	-	281	83	425	227	497	300	569	372	714	516	858	660					
	S10	618	371	-	-	-	-	351	104	423	176	495	248	640	392	784	537					
XL1370 SR	S3	226	136	393	303	569	479	746	655	834	743	922	831	1098	1008	1275	1184					
	S4	302	181	348	227	524	403	700	580	789	668	877	756	1053	932	1229	1109					
	S5	377	226	303	152	479	328	655	504	743	592	831	680	1008	857	1184	1033					
	S5A	415	256	273	114	450	290	626	466	714	555	802	643	978	819	1155	995					
	S6A	491	294	-	-	411	215	587	391	675	479	764	567	940	744	1116	920					
	S8	604	362	-	-	343	101	519	278	607	366	696	454	872	630	1048	807					
	S10	725	483	-	-	-	-	399	157	487	245	575	333	751	510	927	686					
XL2585 SR	S3	428	257	743	571	1076	904	1409	1238	1575	1404	1742	1571	2075	1904	2408	2237					
	S4	570	342	657	429	990	762	1323	1095	1490	1261	1656	1428	1989	1761	2322	2094					
	S5	713	428	571	286	904	619	1238	952	1404	1119	1571	1285	1904	1618	2237	1951					
	S5A	784	483	516	215	849	548	1182	881	1349	1048	1515	1214	1848	1547	2181	1880					
	S6A	927	556	-	-	776	405	1109	739	1276	905	1442	1072	1775	1405	2108	1738					
	S8	1141	684	-	-	648	192	981	525	1147	691	1314	858	1647	1191	1980	1524					
	S10	1369	912	-	-	-	-	753	296	919	463	1086	630	1419	931	1752	1296					
XL4580 SR	S3	755	453	1310	1008	1898	1596	2486	2184	2780	2478	3073	2771	3661	3359							
	S4	1006	604	1159	757	1747	1345	2335	1932	2629	2226	2922	2520	3510	3108							
	S4S	1258	755	1008	505	1596	1093	2184	1681	2478	1974	2771	2268	3359	2856							
	S5A	1384	852	911	379	1498	967	2086	1555	2380	1849	2674	2143	3262	2730							
	S6A	1635	981	-	-	1370	715	1957	1303	2251	1597	2545	1891	3133	2479							
	S8	2013	1208	-	-	1143	338	1731	926	2025	1220	2319	1514	2906	2101</							

DA

Double Acting Actuators Torque Data (Pressures in barg and torques in Nm.)

Torques from air stroke (Nm.) @ given operating air pressure (barg)

Model	3.0 barg	4.0 barg	5.0 barg	5.5 barg	6.0 barg	7.0 barg	8.0 barg	9.0 barg	10.0 barg
XL26 DA	10	14	17	19	21	24	28	31	34
XL71 DA	26	34	43	47	52	60	69	77	86
XL131 DA	49	65	81	89	97	113	129	146	162
XL186 DA	65	87	109	120	131	152	174	196	218
XL221 DA	91	121	152	167	182	212	243	273	303
XL280 DA	109	145	181	199	218	254	290		
XL425 DA	159	212	264	291	317	370	423		
XL680 DA	259	345	431	474	517	603	690		
XL1125 DA	433	577	722	794	866	1010	1155		
XL1370 DA	529	705	882	970	1058	1234	1410		
XL2585 DA	999	1332	1665	1832	1998	2331	2664		
XL4580 DA	1763	2351	2939	3232	3526	4114			

Note: A minimum safety factor of 20% must be added to the actual valve torque before using these charts. When emergency shut down or infrequently used valves are being sized, additional safety factors may be required due to potential increases in the valve torques. If in doubt, or you require any assistance with sizing actuators, please contact HYTORK.

Envelope Dimensions XL26 to XL221

Spring Return and Double Acting Units

Model	XL26	XL71	XL131	XL186	XL221
A	97	115	131	137	153
B	77	95	111	117	133
C	45	57	64	71	78
D	52	59	70	72	81
E	165	222	293	332	350
F	29	29	30	30	33
G	86	102	121	126	141

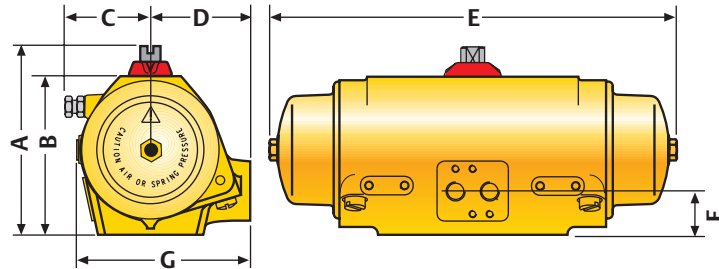

Envelope Dimensions XL280 to XL4580

Spring Return

Model	XL280	XL425	XL680	XL1125	XL1370	XL2585	XL4580
A	173	167	201	231	246	291	387
B	153	147	181	201	216	261	357
C	87	86	95	116	124	N/A	N/A
D	87	89	99	109	117	137	162
E	358	447	566	641	683	804	862
F	44	41	52	56	51	49	76
G	158	162	181	205	222	264	327
H	254	310	336	393	397	467	525

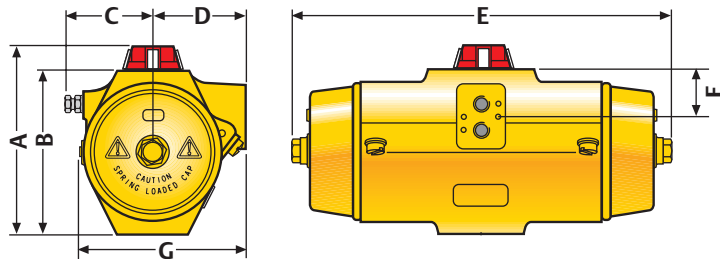

Double Acting

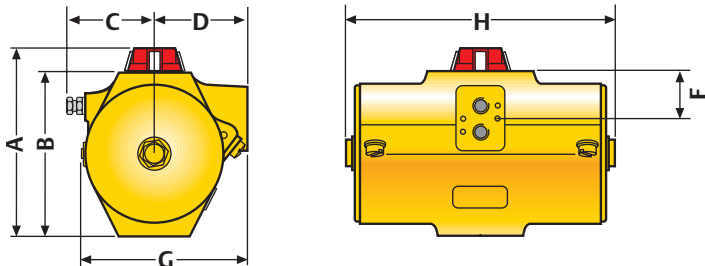

ISO 5211 Standard Drive & Bottom Mounting Details XL26 to XL4580

ISO 5211 Bottom Mounting Details

Model	ISO	A	B	C	D	E	F	G	H	ØJ	ØK	L
XL26	F05	M6	9.0	50.0	M6	9.0	35.35	90.0	35.35	27.8	34.97/34.94	3.0
XL71	F07	M8	12.0	70.0	M8	12.0	49.5	114.0	49.5	46.0	54.97/54.92	3.0
XL131	F07	M8	12.0	70.0	M8	12.0	49.5	114.0	49.5	46.0	54.97/54.92	3.0
XL186	F07	M8	12.0	70.0	M8	12.0	49.5	114.0	49.5	46.0	54.97/54.92	3.0
XL221	F07	M8	12.0	70.0	M8	12.0	49.5	114.0	49.5	46.0	54.97/54.92	3.0

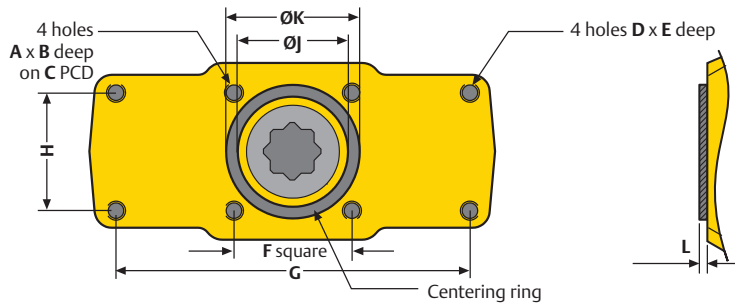

Models shown with optional Centering Ring fitted

Models with additional ISO 5211 Bottom Mounting Details

Model	ISO	A	B	C	D
XL26	F03	M5	8.0	36.0	25.46
XL71	F05	M6	9.0	50.0	35.35
XL131	F05	M6	9.0	50.0	35.35

Models shown with optional Centering Ring removed to reveal additional ISO mounting holes

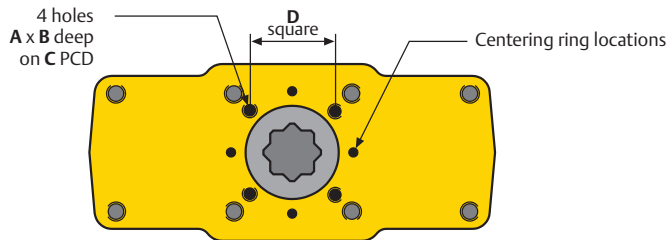

ISO 5211 Bottom Mounting Details

Model	ISO	A	B	C	D	ØE	ØF	G
XL280	F07	M8	12.0	70.0	49.5	54.97/54.92	45.0	3.0
XL425	F10	M10	15.0	102.0	72.1	69.97/69.92	65.0	3.0
XL680	F10	M10	15.0	102.0	72.1	69.97/69.92	60.0	3.0
XL1125	F12	M12	18.0	125.0	88.4	84.96/84.91	75.0	3.0
XL1370	F12	M12	18.0	125.0	88.4	84.96/84.91	75.0	3.0
XL2585	F16	M20	20.0	165.0	116.7	129.95/129.89	115.0	5.0
XL4580	F16	M20	25.0	165.0	116.7	129.95/129.89	115.0	5.0

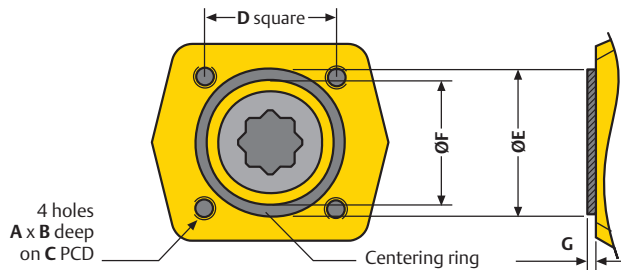

ISO 5211 Standard Drive Details

Model	ISO	A	B	C	D	E	F
XL26	F05	18.1	28.0	14.7	16.0	14.00/14.11	-
XL71	F07	22.2	45.0	17.9	19.0	17.00/17.11	-
XL131	F07	22.2	45.0	17.9	19.0	17.00/17.11	-
XL186	F07	22.2	45.0	17.9	19.0	17.00/17.11	-
XL221	F07	22.2	45.0	17.9	19.0	17.00/17.11	-
XL280	F07	22.2	45.0	17.9	19.0	17.00/17.11	-
XL425	F10	28.2	60.0	23.1	24.0	22.00/22.13	30.0
XL680	F10	28.2	60.0	23.1	24.0	22.00/22.13	30.0
XL1125	F12	36.2	72.0	28.4	29.0	27.00/27.13	25.0
XL1370	F12	36.2	72.0	28.4	29.0	27.00/27.13	25.0
XL2585	F16	60.2	100.0	48.5	48.0	46.00/46.16	35.0
XL4580	F16	60.2	100.0	48.5	48.0	46.00/46.16	35.0

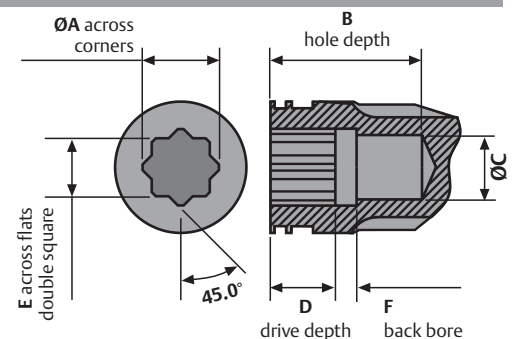

VDI/VE Pinion Top Details

Model	ØA	ØB	C	D	E
XL26	24.6/24.5	16.6/16.5	14.00/13.85	20.1/19.9	16.4/16.0
XL71	24.6/24.5	16.6/16.5	14.00/13.85	20.1/19.9	16.4/16.0
XL131	24.6/24.5	16.6/16.5	14.00/13.85	20.1/19.9	16.4/16.0
XL186	30.5/30.0	16.6/16.5	14.00/13.85	20.1/19.9	13.7/13.3
XL221	30.5/30.0	16.6/16.5	14.00/13.85	20.1/19.9	13.7/13.3
XL280	44.5/44.0	23.5/23.3	17.00/16.85	20.1/19.9	12.6/12.4
XL425	64.5/64.0	43.5/43.3	22.00/21.85	20.1/19.9	12.6/12.4
XL680	69.5/69.0	43.5/43.3	22.00/21.85	20.1/19.9	12.6/12.4
XL1125	90.5/90.0	67.1/66.9	36.00/35.85	30.1/29.9	18.1/17.9
XL1370	90.5/90.0	67.1/66.9	36.00/35.85	30.1/29.9	18.1/17.9
XL2585	95.5/95.0	71.5/71.3	40.00/39.85	30.1/29.9	18.1/17.9
XL4580	95.5/95.0	71.5/71.3	40.00/39.85	30.1/29.9	18.1/17.9

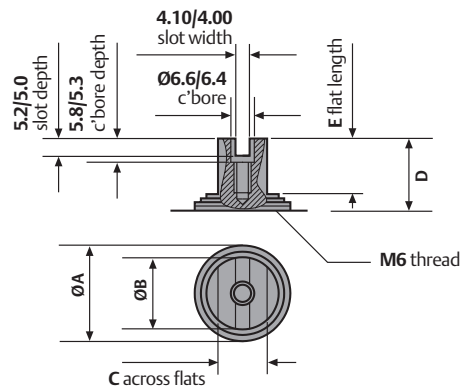

VDI/VE Top Mounting Details

Model	A	B	C	D	E
XL26	M5	6.25	30.0	80.0	N/A
XL71	M5	6.25	30.0	80.0	N/A
XL131	M5	6.25	30.0	80.0	130.0
XL186	M5	6.25	30.0	80.0	130.0
XL221	M5	6.25	30.0	80.0	130.0

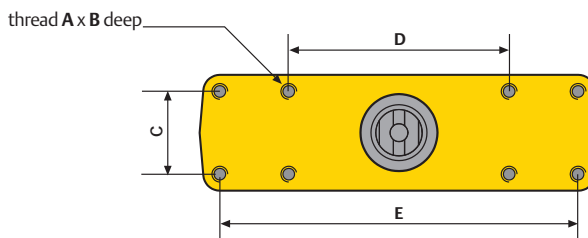

VDI/VE & ISO 5211 Top Mounting Details

Model	ISO	A	B	C	D	E	F	G	H
XL280	F07	M8	12.0	70.0	30.0	49.5	80.0	M5	8.0
XL425	F10	M10	15.0	102.0	30.0	72.1	80.0	M5	8.0
XL680	F10	M10	15.0	102.0	30.0	72.1	80.0	M5	8.0
XL1125	F12	M12	18.0	125.0	30.0	88.4	130.0	M5	8.0
XL1370	F12	M12	18.0	125.0	30.0	88.4	130.0	M5	8.0
XL2585	F16	M20	20.0	165.0	30.0	116.7	130.0	M5	8.0
XL4580	F16	M20	25.0	165.0	30.0	116.7	130.0	M5	8.0

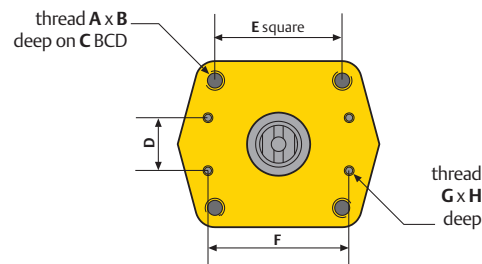

Namur Solenoid Mounting Details XL26 to XL221

Model	A	B	C	D	E	F	G	H
XL26 to XL221	M5	8.0	16.0	32.0	12.0	24.0	1/4" BSP	12.0

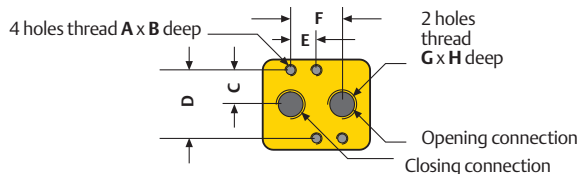

Namur Solenoid Mounting Details XL280 to XL4580

Model	A	B	C	D	E	F	G	H
XL280 to XL4580	M5	8.0	16.0	32.0	12.0	24.0	1/4" BSP	12.0

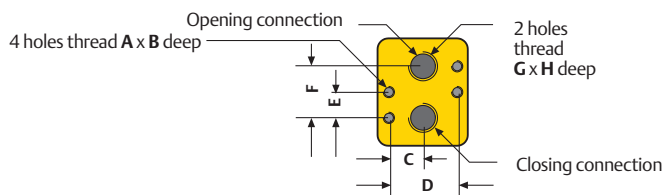

Optional Highflow 1/2" BSP XL2585 to XL4580

Model	A	B	C	D	E	F	G	H	J	K	L
XL2585 to XL4580	M6	8.0	23.0	46.0	20.5	33.0	1/2" BSP	18.0	25.4	63.5	82.0

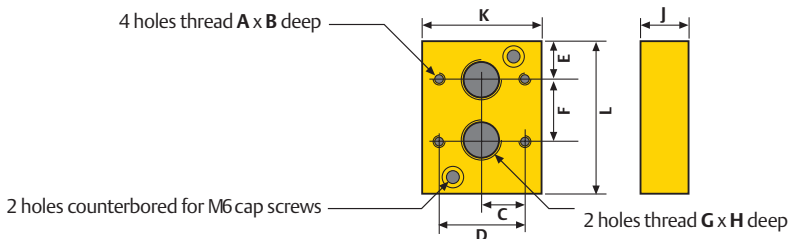

Air Volume & Consumption, Actuator weights & Speeds

Air Consumption XL26 to XL4580 (Pressures in barg & units in cubic centimetres)

Air consumed on **OUTWARD** stroke (Absolute)

Model	3.0 barg	4.0 barg	5.0 barg	5.5 barg	6.0 barg	7.0 barg	8.0 barg	10.0 barg
XL26	320	406	492	535	578	664	750	922
XL71	817	1037	1257	1367	1477	1697	1917	2357
XL131	1599	2029	2459	2674	2889	3319	3749	4609
XL186	2115	2685	3255	3540	3825	4395	4965	6105
XL221	2802	3562	4322	4702	5082	5842	6602	8122
XL280	3473	4412	5351	5821	6290	7229	8168	10046
XL425	5143	6510	7877	8561	9244	10611	11978	14712
XL680	7655	9688	11721	12737	13754	15787	17820	21886
XL1125	12447	15761	19075	20732	22389	25703	29017	35645
XL1370	15684	19853	24022	26106	28191	32360	36529	44867
XL2582	28579	36112	43645	47411	51178	58711	66244	81310
XL4580	47894	60355	72816	79046	85277	97738	110199	135121

Air consumed on **INWARD** stroke (Absolute)

Model	3.0 barg	4.0 barg	5.0 barg	5.5 barg	6.0 barg	7.0 barg	8.0 barg	10.0 barg
XL26	449	580	710	775	840	970	1100	1360
XL71	1232	1594	1954	2134	2314	2674	3034	3754
XL131	2543	3292	4037	4410	4782	5527	6272	7762
XL186	3333	4313	5288	5776	6263	7238	8213	10163
XL221	4434	5748	7055	7708	8362	9669	10976	13590
XL280	3584	4571	5550	6040	6529	7508	8487	10445
XL425	4623	5857	7079	7690	8301	9523	10745	13189
XL680	7916	10064	12192	13256	14320	16448	18576	22832
XL1125	12196	15484	18740	20368	21996	25252	28508	35020
XL1370	15268	19369	23430	25461	27491	31552	35613	43735
XL2582	26992	34126	41184	44713	48242	55300	62358	76474
XL4580	50947	64648	78216	85000	91784	105352	118920	146056

Actuator Weights XL26 to XL4580

(Units in Kilograms)

	Double Acting	Spring Return with S80 Springs
XL26	1.39 Kgs	1.53 Kgs
XL71	2.39 Kgs	2.78 Kgs
XL131	3.90 Kgs	4.76 Kgs
XL186	4.77 Kgs	5.45 Kgs
XL221	6.19 Kgs	7.76 Kgs
XL280	6.80 Kgs	9.90 Kgs
XL425	9.50 Kgs	12.50 Kgs
XL680	13.40 Kgs	22.50 Kgs
XL1125	22.00 Kgs	36.00 Kgs
XL1370	27.00 Kgs	46.60 Kgs
XL2585	46.00 Kgs	79.00 Kgs
XL4580	83.00 Kgs	142.00 Kgs



Actuator Operating Speeds XL26 to XL4580 (Operating Pressure = 80PSI)

(Time in seconds)

Model	Double Acting		Spring Return with S80 Springs	
	Opening Stroke	Closing Stroke	Opening Stroke	Closing Stroke
XL26	0.01	0.01	0.05	0.02
XL71	0.03	0.03	0.09	0.05
XL131	0.03	0.04	0.15	0.09
XL186	0.05	0.06	0.19	0.12
XL221	0.06	0.08	0.24	0.15
XL280	0.20	0.10	0.10	0.20
XL425	0.20	0.30	0.30	0.50
XL680	0.40	0.60	0.40	1.20
XL1125	0.70	0.60	0.50	0.70
XL1370	0.80	0.70	0.70	1.00
XL2585	1.50	1.20	1.20	1.50
XL4580	2.00	2.90	2.20	3.90

Free Air Volume at Atmospheric Pressure XL4580

(Units in Cubic Centimetres - CC)

Double Acting and Spring Return

Model	Central Chamber		Displaced Volume
	Open	Closed	
XL26	86	25	61
XL71	220	65	155
XL131	430	125	305
XL186	570	170	400
XL221	760	245	515
XL280	939	291	648
XL425	1367	338	1029
XL680	2033	497	1536
XL1125	3314	841	2473
XL1370	4169	1033	3136
XL2582	7533	1630	5903
XL4580	12461	2085	10376

Spring Return & Double Acting Actuators

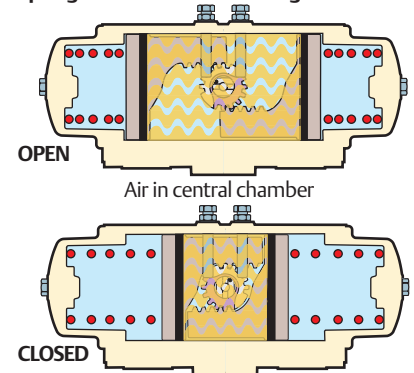

Double Acting ONLY

Model	End Chambers		Displaced Volume
	Open	Closed	
XL26	71	130	59
XL71	208	360	152
XL131	437	745	308
XL186	567	975	408
XL221	794	1307	513
XL280	332	979	647
XL425	265	1222	957
XL680	596	2128	1532
XL1125	828	3256	2428
XL1370	976	4061	3085
XL2582	1240	7058	5818
XL4580	3325	13618	10243

Double Acting Actuators

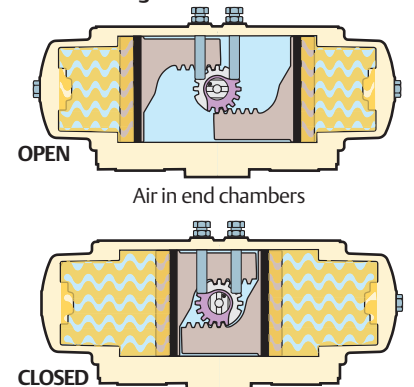



Spring Return Actuators Torque Data (Pressures in psig and torques in inch pounds.)

Torques from air stroke (ins. lbs.) @ given operating air pressure (psig)

Model	Spring Rating	Torque from Springs		40 Psi		50 Psi		60 Psi		70 Psi		80 Psi		90 Psi		100 Psi		120 Psi		150 Psi	
		Start	End	Start	End	Start	End	Start	End	Start	End	Start	End	Start	End	Start	End	Start	End	Start	End
XL26 SR	S4	53	32	52	31	73	52	94	73	115	94	135	114	156	135	177	156	219	198	281	260
	S5	66	39	44	18	65	39	86	60	107	80	128	101	148	122	169	143	211	185	274	247
	S6	79	47	-	-	57	26	78	46	99	67	120	88	141	109	161	130	203	172	266	234
	S7	92	55	-	-	-	-	70	33	91	54	112	75	133	96	153	117	195	158	258	221
	S8	105	63	-	-	-	-	62	20	83	41	104	62	125	83	146	104	187	145	250	208
	S9	118	71	-	-	-	-	-	-	75	28	96	49	117	70	138	90	179	132	242	195
S10	131	79	-	-	-	-	-	-	-	-	88	36	109	57	130	77	172	119	234	182	
XL71 SR	S4	131	79	130	77	182	130	234	182	286	234	338	286	391	338	443	390	547	495	704	651
	S5	164	98	110	45	162	97	214	149	267	201	319	253	371	305	423	357	527	462	684	618
	S6	197	118	-	-	143	64	195	116	247	168	299	220	351	273	403	325	508	429	664	585
	S7	230	138	-	-	-	-	175	83	227	135	279	188	332	240	384	292	488	396	645	553
	S8	263	158	-	-	-	-	155	50	208	103	260	155	312	207	364	259	468	363	625	520
	S9	295	177	-	-	-	-	-	-	188	70	240	122	292	174	344	226	449	331	605	487
S10	328	197	-	-	-	-	-	-	-	-	220	89	273	141	325	193	429	298	585	454	
XL131 SR	S4	247	148	244	146	342	244	440	342	539	440	637	538	735	636	833	734	1029	930	1232	1225
	S5	309	185	207	84	305	182	403	280	502	378	600	476	698	574	796	672	992	869	1286	1163
	S6	370	222	-	-	268	120	366	218	465	316	563	414	661	513	759	611	955	807	1249	1101
	S7	432	259	-	-	-	-	329	157	427	255	526	353	624	451	722	549	918	745	1212	1039
	S8	494	296	-	-	-	-	292	95	390	193	489	291	587	389	685	487	881	683	1175	978
	S9	555	333	-	-	-	-	-	-	353	131	452	229	550	327	648	426	844	622	1138	916
S10	617	370	-	-	-	-	-	-	-	-	414	168	513	266	611	364	807	560	1101	854	
XL186 SR	S4	331	198	329	197	461	329	593	461	725	593	857	725	989	857	1121	989	1385	1253	1781	1648
	S5	413	248	280	115	412	247	543	379	675	510	807	642	939	774	1071	906	1335	1170	1731	1566
	S6	495	298	-	-	362	164	494	296	626	428	757	560	889	692	1021	824	1285	1088	1681	1483
	S7	578	347	-	-	312	81	444	213	576	345	708	477	840	609	972	741	1236	1005	1632	1401
	S8	661	397	-	-	-	-	395	130	527	262	659	394	791	526	923	658	1186	922	1582	1318
	S9	744	446	-	-	-	-	-	-	477	180	609	311	741	443	873	575	1137	839	1533	1235
S10	827	495	-	-	-	-	-	-	-	-	560	229	692	361	824	492	1088	756	1483	1152	
XL221 SR	S4	463	278	458	273	641	456	825	640	1009	824	1193	1008	1377	1192	1560	1375	1928	1743	2479	2294
	S5	578	347	388	157	572	341	756	525	940	708	1123	892	1307	1076	1491	1260	1859	1627	2410	2179
	S6	694	416	-	-	503	225	686	409	870	593	1054	777	1238	960	1422	1144	1789	1512	2341	2063
	S7	809	486	-	-	-	-	617	293	801	477	985	661	1168	845	1352	1028	1720	1396	2271	1947
	S8	925	555	-	-	-	-	548	178	731	361	915	545	1099	729	1283	913	1650	1280	2202	1832
	S9	1041	624	-	-	-	-	-	-	662	246	846	430	1030	613	1213	797	1581	1165	2132	1716
S10	1156	694	-	-	-	-	-	-	-	-	777	314	960	498	1144	682	1512	1049	2063	1601	
XL280 SR	S4	550	330	550	330	769	549	989	769	1209	989	1429	1209	1649	1429	1869	1649	2309	2089		
	S6	824	495	-	-	604	275	824	495	1044	715	1264	935	1484	1155	1704	1375	2144	1815		
	S8	1099	660	-	-	-	-	659	220	879	440	1099	660	1319	880	1539	1100	1979	1540		
	S10	1374	824	-	-	-	-	-	-	-	-	935	385	1155	605	1375	825	1815	1265		
XL425 SR	S3	601	361	922	682	1242	1002	1563	1323	1883	1643	2204	1964	2525	2285	2845	2605	3487	3247		
	S4	802	481	802	481	1122	801	1443	1122	1763	1442	2084	1763	2405	2084	2725	2404	3367	3046		
	S5	1002	601	682	281	1002	601	1323	922	1643	1242	1964	1563	2285	1884	2605	2204	3247	2846		
	S5A	1102	679	604	181	924	501	1245	822	1565	1142	1886	1463	2207	1784	2527	2104	3169	2746		
	S6A	1303	782	-	-	821	300	1142	621	1462	941	1783	1262	2104	1583	2424	1903	3066	2545		
	S8	1603	962	-	-	-	-	962	321	1282	641	1603	962	1924	1283	2244	1603	2886	2245		
S10	1924	1283	-	-	-	-	-	-	961	320	1282	641	1603	962	1923	1282	2565	1924			
XL680 SR	S3	980	588	1503	1111	2025	1633	2548	2156	3070	2678	3593	3201	4116	3724	4638	4246	5684	5292		
	S4	1306	784	1307	785	1829	1307	2352	1830	2874	2352	3397	2875	3920	3398	4442	3920	5488	4966		
	S5	1633	980	1111	458	1633	980	2156	1503	2678	2025	3201	2548	3724	3071	4246	3593	5292	4639		
	S5A	1796	1106	985	295	1507	817	2030	1340	2552	1862	3075	2385	3598	2908	4120	3430	5166	4476		
	S6A	2123	1274	-	-	1339	490	1862	1013	2384	1535	2907	2058	3430	2581	3952	3103	4998	4149		
	S8	2613	1568	-	-	-	-	1568	523	2090	1045	2613	1568	3136	2091	3658	2613	4704	3659		
S10	3135	2090	-	-	-	-	-	-	1568	523	2091	1046	2614	1569	3136	2091	4182	3137			
XL1125 SR	S4	2188	1313	2187	1312	3062	2187	3937	3062	4812	3937	5687	4812	6562	5687	7437	6562	9187	8312		
	S6	3281	1969	-	-	2406	1094	3281	1969	4156	2844	5031	3719	5906	4594	6781	5469	8531	7219		
	S8	4375	2625	-	-	-	-	2625	875	3500	1750	4375	2625	5250	3500	6125	4375	7875	6125		
	S10	5469	3281	-	-	-	-	-	-	-	-	3719	1531	4594	2406	5469	3281	7219	5031		
	S3	2004	1202	3073	2271	4142	3340	5211	4409	6279	5477	7348	6546	8417	7615	9486	8684	11623	10821		
	S4	2672	1603	2672	1603	3741	2672	4810	3741	5878	4809	6947	5878	8016	6947	9085	8016	11222	10153		
S5	3340	2004	2271	935	3340	2004	4409	3073	5477	4141	6546	5210	7615	6279	8684	7348	10821	9485			
S5A	3674	2263	2012	601	3081	1670	4150	2739	5218	3807	6287	4876	7356	5945	8425	7014	10562	9151			
S6A	4342	2605	-	-	2739	1002	3808	2071	4876	3139	5945	4208	7014	5277	8083	6346	10220	8483			
S8	5344	3206	-	-	-	-	3207	1069	4275	2137	5344	3206	6413	4275	7482	5344	9619	7481			
S10	6413	4275	-	-	-	-	-	-	3206	1068	4275	2137	5344	3206	6413	4275	8550	6412			
XL2585 SR	S3	3785	2271	5804	4290	7823	6309	9842	8328	11860	10346	13879	12365	15898	14384	17917	16475	21954	20440		
	S4	5047	3028	5047	3028	7066	5047	9085	7066	11103	9084	13122	11103	15141	13122	17160	15141	21197	19178		
	S5	6309	3785	4290	1766	6309	3785	8328	5804	10346	7822	12365	9841	14384	11860	16403	13879	20440	17916		
	S5A	6939	4275	3800	1136	5819	3155	7838	5174	9856	7192	11875	9211	13894	11230	15913	13249	19950	17286		
	S6A	8201	4921	-	-	5173	1893	7192	3912	9210	5930	11229	7949	13248	9968	15267	11987	19304	16024		
	S8	10094	6056	-	-	-	-	6057	2019	8075	4037	10094	6056	12113	8075	14132	10094	18169	14131		

DA

**Double Acting Actuators Torque Data (Pressures in psig and torques in inch. pounds.)
Torques from air stroke (ins. lbs.) @ given operating air pressure (psig)**

Model	40Psi	50Psi	60Psi	70Psi	80Psi	90Psi	100Psi	120Psi	150Psi
XL26 DA	83	104	125	146	167	188	209	250	313
XL71 DA	209	261	313	365	417	469	521	626	782
XL131 DA	392	490	589	687	785	883	981	1177	1471
XL186 DA	528	660	791	923	1055	1187	1319	1583	1979
XL221 DA	735	919	1103	1286	1470	1654	1838	2205	2757
XL280 DA	879	1099	1319	1539	1759	1979	2199	2638	
XL425 DA	1282	1603	1924	2244	2565	2886	3206	3847	
XL680 DA	2090	2613	3136	3658	4181	4704	5226	6271	
XL1125 DA	3500	4375	5250	6125	7000	7875	8750	10500	
XL1370 DA	4275	5344	6412	7481	8550	9619	10687	12825	
XL2585 DA	8075	10094	12112	14131	16150	18169	20187	24225	
XL4580 DA	14250	17812	21375	24937	28500	32062	35625		

Note: A minimum safety factor of 25% must be added to the actual valve torque before using these charts. When emergency shut down or infrequently used valves are being sized, additional safety factors may be required due to potential increases in the valve torques. If in doubt, or you require any assistance with sizing actuators, please contact HYTORK.

**Envelope Dimensions XL26 to XL4580
Spring Return and Double Acting Units**

Model	XL26	XL71	XL131	XL186	XL221
A	3.82"	4.53"	5.16"	5.39"	6.01"
B	3.04"	3.74"	4.37"	4.59"	5.22"
C	1.77"	2.24"	2.52"	2.80"	3.07"
D	2.05"	2.34"	2.74"	2.84"	3.17"
E	6.50"	8.73"	11.54"	13.06"	13.77"
F	1.14"	1.14"	1.20"	1.20"	1.30"
G	3.38"	4.01"	4.76"	4.96"	5.57"

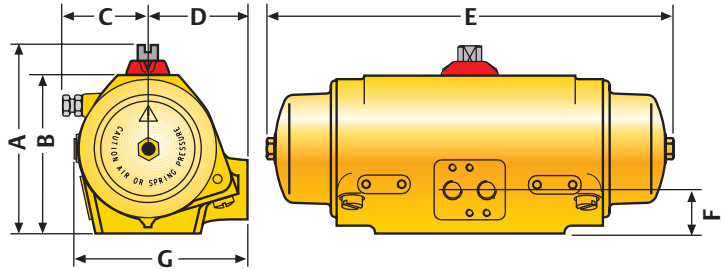

Spring Return

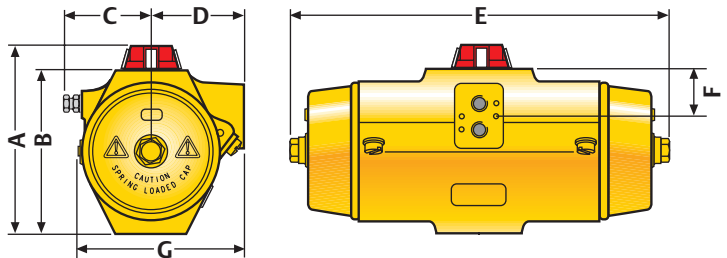

Double Acting

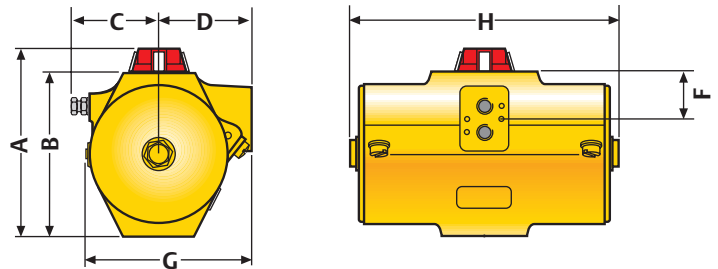

Model	XL280	XL425	XL680	XL1125	XL1370	XL2585	XL4580
A	6.81"	6.57"	7.91"	9.09"	9.69"	11.46"	15.24"
B	6.02"	5.79"	7.13"	7.91"	8.50"	10.28"	14.06"
C	3.43"	3.38"	3.74"	4.57"	4.88"	N/A	N/A
D	3.43"	3.50"	3.90"	4.29"	4.61"	5.39"	6.38"
E	14.09"	17.60"	22.28"	25.24"	26.89"	31.65"	33.94"
F	1.73"	1.61"	2.05"	2.22"	1.99"	1.93"	2.98"
G	6.22"	6.38"	7.13"	8.07"	8.74"	10.39"	12.87"
H	10.00"	12.20"	13.23"	15.47"	15.63"	18.39"	20.67"

ISO 5211 Standard Drive & Bottom Mounting Details XL26 to XL4580

ISO 5211 Bottom Mounting Details

Model	ISO	A unc	B	C	D unc	E	F	G	H	ØJ	ØK	L
XL26	F05	1/4"	0.35"	1.97"	1/4"	0.35"	1.39"	3.54"	1.39"	1.09"	1.376/1.375"	0.12"
XL71	F07	5/16"	0.47"	2.76"	5/16"	0.47"	1.95"	4.49"	1.95"	1.81"	2.164/2.162"	0.12"
XL131	F07	5/16"	0.47"	2.76"	5/16"	0.47"	1.95"	4.49"	1.95"	1.81"	2.164/2.162"	0.12"
XL186	F07	5/16"	0.47"	2.76"	5/16"	0.47"	1.95"	4.49"	1.95"	1.81"	2.164/2.162"	0.12"
XL221	F07	5/16"	0.47"	2.76"	5/16"	0.47"	1.95"	4.49"	1.95"	1.81"	2.164/2.162"	0.12"

Models shown with optional Centering Ring fitted

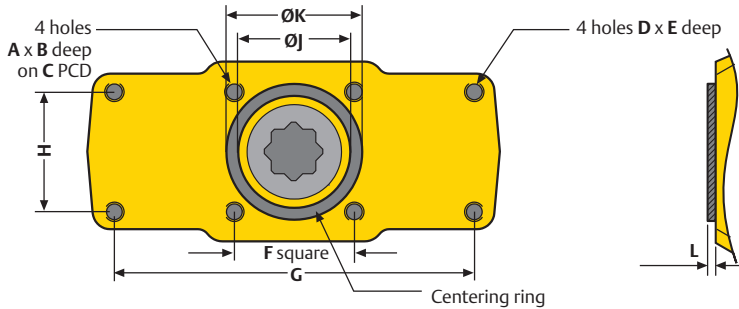

Models with additional ISO 5211 Bottom Mounting Details

Model	ISO	A unc	B	C	D
XL26	F03	No 10x24	0.32"	1.42"	1.00"
XL71	F05	1/4"	0.35"	1.97"	1.39"
XL131	F05	1/4"	0.35"	1.97"	1.39"

Models shown with optional Centering Ring removed to reveal additional ISO mounting holes

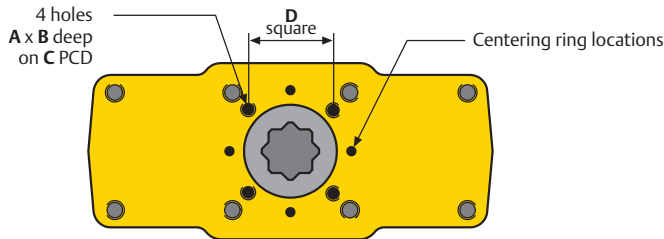

ISO 5211 Bottom Mounting Details

Model	ISO	A unc	B	C	D
XL280	F07	5/16"	0.47"	2.76"	1.95"
XL425	F10	3/8"	0.59"	4.02"	2.84"
XL680	F10	3/8"	0.59"	4.02"	2.84"
XL1125	F12	1/2"	0.71"	4.92"	3.48"
XL1370	F12	1/2"	0.71"	4.92"	3.48"
XL2585	F16	3/4"	0.79"	6.50"	4.59"
XL4580	F16	3/4"	0.98"	6.50"	4.59"

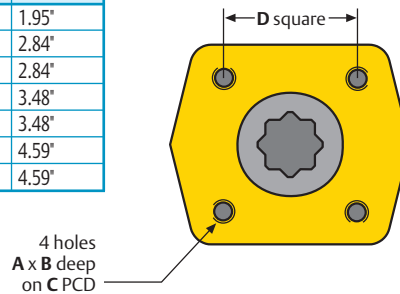

ISO 5211 Standard Drive Details

Model	ISO	A	B	ØC	D	E	F
XL26	F05	0.71"	1.1"	0.6"	0.630"	0.551/0.555"	-
XL71	F07	0.87"	1.8"	0.7"	0.748"	0.669/0.673"	-
XL131	F07	0.87"	1.8"	0.7"	0.748"	0.669/0.673"	-
XL186	F07	0.87"	1.8"	0.7"	0.748"	0.669/0.673"	-
XL221	F07	0.87"	1.8"	0.7"	0.748"	0.669/0.673"	-
XL280	F07	0.87"	1.8"	0.7"	0.748"	0.669/0.673"	-
XL425	F10	1.11"	2.3"	0.9"	0.945"	0.866/0.871"	1.18"
XL680	F10	1.11"	2.3"	0.9"	0.945"	0.866/0.871"	1.18"
XL1125	F12	1.43"	2.8"	1.1"	1.142"	1.063/1.068"	1.00"
XL1370	F12	1.43"	2.8"	1.1"	1.142"	1.063/1.068"	1.00"
XL2585	F16	2.37"	3.9"	1.9"	1.890"	1.811/1.817"	1.38"
XL4580	F16	2.37"	3.9"	1.9"	1.890"	1.811/1.817"	1.38"

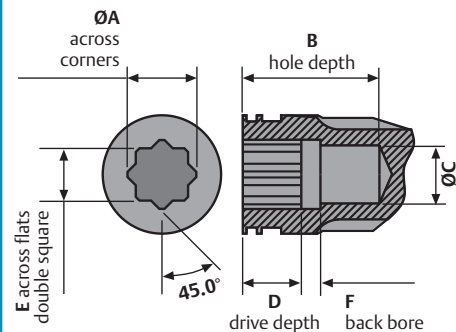

VDI/VDE Pinion Top Details

Model	ØA	ØB	C	D	E
XL26	0.969/0.965"	0.653/0.650"	0.551/0.545"	0.79/0.78"	0.645/0.630"
XL71	0.969/0.965"	0.653/0.650"	0.551/0.545"	0.79/0.78"	0.645/0.630"
XL131	1.20/1.18"	0.653/0.650"	0.551/0.545"	0.79/0.78"	0.645/0.630"
XL186	1.20/1.18"	0.653/0.650"	0.551/0.545"	0.79/0.78"	0.540/0.523"
XL221	1.20/1.18"	0.653/0.650"	0.551/0.545"	0.79/0.78"	0.540/0.523"
XL280	1.75/1.73"	0.925/0.917"	0.670/0.663"	0.79/0.78"	0.496/0.489"
XL425	2.54/2.52"	1.713/1.705"	0.866/0.860"	0.79/0.78"	0.496/0.489"
XL680	2.54/2.52"	1.713/1.705"	0.866/0.860"	0.79/0.78"	0.496/0.489"
XL1125	3.56/3.54"	2.642/2.634"	1.417/1.411"	1.185/1.177"	0.712/0.705"
XL1370	3.56/3.54"	2.642/2.634"	1.417/1.411"	1.185/1.177"	0.712/0.705"
XL2585	3.76/3.74"	2.815/2.807"	1.575/1.569"	1.185/1.177"	0.712/0.705"
XL4580	3.76/3.74"	2.815/2.807"	1.575/1.569"	1.185/1.177"	0.712/0.705"

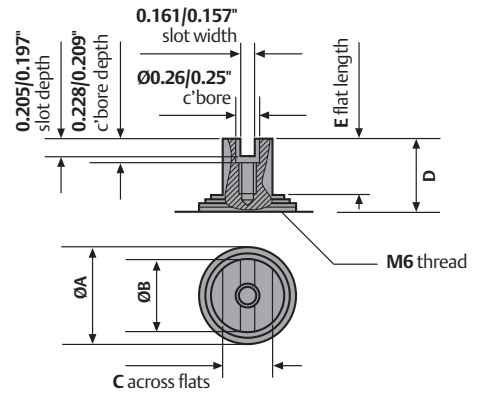

VDI/VDE Top Mounting Details

Model	A unc	B	C	D	E
XL26	No10x24	0.24"	1.18"	3.15"	N/A
XL71	No10x24	0.24"	1.18"	3.15"	N/A
XL131	No10x24	0.24"	1.18"	3.15"	5.12"
XL186	No10x24	0.24"	1.18"	3.15"	5.12"
XL221	No10x24	0.24"	1.18"	3.15"	5.12"

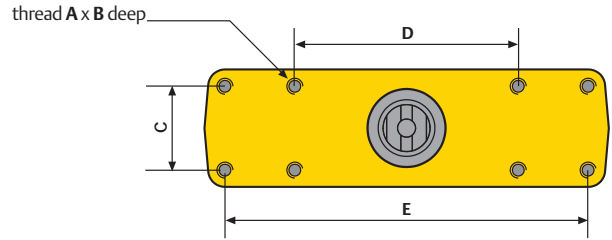

VDI/VDE & ISO 5211 Top Mounting Details

Model	ISO	A unc	B	C	D	E	F	G unc	H
XL280	F07	5/16"	0.47"	2.76"	1.18"	1.95"	3.15"	No10x24	0.315"
XL425	F10	3/8"	0.59"	4.02"	1.18"	2.84"	3.15"	No10x24	0.315"
XL680	F10	3/8"	0.59"	4.02"	1.18"	2.84"	3.15"	No10x24	0.315"
XL1125	F12	1/2"	0.71"	4.92"	1.18"	3.48"	5.12"	No10x24	0.315"
XL1370	F12	1/2"	0.71"	4.92"	1.18"	3.48"	5.12"	No10x24	0.315"
XL2585	F16	3/4"	0.79"	6.50"	1.18"	4.59"	5.12"	No10x24	0.315"
XL4580	F16	3/4"	0.98"	6.50"	1.18"	4.59"	5.12"	No10x24	0.315"

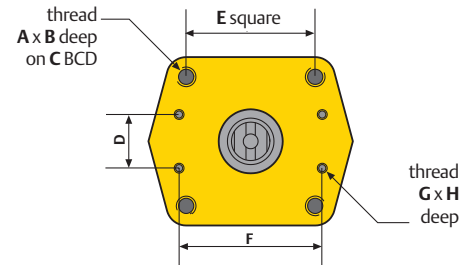

Namur Solenoid Mounting Details XL26 to XL221

Model	A	B	C	D	E	F	G	H
XL26 to XL221	No10x24	0.315"	0.63"	1.26"	0.47"	0.94"	1/4" NPT	0.47"

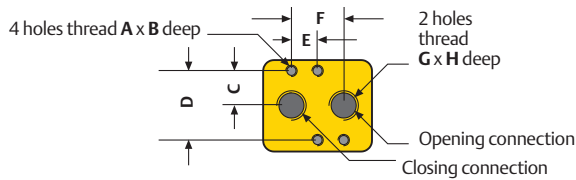

Namur Solenoid Mounting Details XL280 to XL4580

Model	A unc	B	C	D	E	F	G	H
XL280 to XL4580	No10x24	0.315"	0.63"	1.26"	0.47"	0.94"	1/4" NPT	0.47"

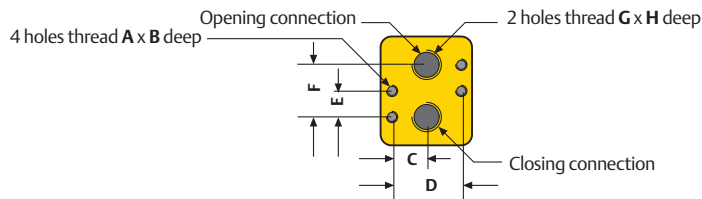

Optional Highflow 1/2" NPT XL2585 to XL4580

Model	A unc	B	C	D	E	F	G	H	J	K	L
XL2585 to XL4580	1/4"	0.315"	0.90"	1.80"	0.80"	1.30"	1/2" NPT	0.55"	1.0"	2.5"	3.25"

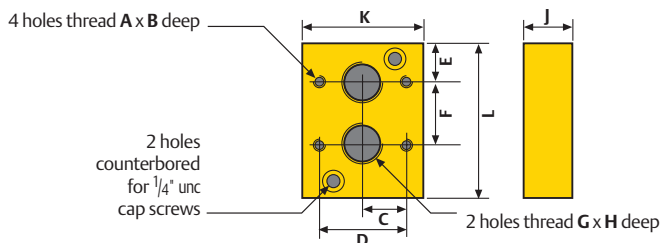

Air Consumption XL26 to XL4580 (Pressures in psig & units in cubic inches)

Air consumed on OUTWARD stroke (Absolute)

Model	40 Psi	50 Psi	60 Psi	70 Psi	80 Psi	90 Psi	100 Psi	120 Psi	150 Psi
XL26	265	317	370	422	475	527	580	684	842
XL71	676	810	945	1079	1213	1347	1482	1750	2153
XL131	1323	1586	1848	2110	2373	2635	2898	3422	4210
XL186	1750	2098	2446	2794	3142	3489	3837	4533	5576
XL221	2317	2781	3245	3708	4172	4636	5100	6027	7419
XL280	2873	3446	4019	4592	5165	5738	6311	7457	9176
XL425	4260	5094	5928	6762	7597	8431	9265	10933	13436
XL680	6340	7581	8822	10062	11303	12543	13784	16265	19987
XL1125	10308	12330	14352	16375	18397	20419	22442	26486	32553
XL1370	12989	15534	18078	20622	23166	25710	28254	33342	40974
XL2582	23683	28280	32877	37474	42071	46668	51264	60458	74249
XL4580	39724	47329	54933	62537	70141	77745	85349	100558	123370

Air consumed on INWARD stroke (Absolute)

Model	40 Psi	50 Psi	60 Psi	70 Psi	80 Psi	90 Psi	100 Psi	120 Psi	150 Psi
XL26	370	450	529	608	688	767	846	1005	1243
XL71	1015	1235	1454	1674	1894	2114	2333	2773	3432
XL131	2095	2549	3004	3459	3913	4368	4823	5732	7096
XL186	2746	3341	3936	4531	5126	5721	6316	7506	9291
XL221	3651	4448	5246	6043	6841	7638	8436	10031	12424
XL280	2970	3568	4165	4762	5360	5957	6555	7749	9542
XL425	3841	4587	5333	6078	6824	7570	8316	9807	12044
XL680	6569	7867	9166	10464	11763	13062	14360	16957	20853
XL1125	10126	12113	14100	16087	18073	20060	22047	26021	31982
XL1370	12680	15158	17636	20115	22593	25071	27549	32505	39940
XL2582	22447	26754	31061	35368	39675	43983	48290	56904	69825
XL4580	42307	50587	58867	67146	75426	83706	91985	108545	133384

Actuator Weights XL26 to XL4580

(Units in POUNDS)

Model	Double Acting	Spring Return with S80 Springs
XL26	3.06Lbs	3.37Lbs
XL71	5.27Lbs	6.13Lbs
XL131	8.60Lbs	10.49Lbs
XL186	10.52Lbs	12.02Lbs
XL221	13.65Lbs	17.11Lbs
XL280	14.99Lbs	21.83Lbs
XL425	20.94Lbs	27.56Lbs
XL680	29.54Lbs	49.60Lbs
XL1125	48.50Lbs	79.37Lbs
XL1370	59.52Lbs	102.73Lbs
XL2582	101.41Lbs	174.16Lbs
XL4580	182.98Lbs	313.05Lbs



Actuator Operating Speeds XL26 to XL4580 (Operating Pressure = 80PSI)

(Time in seconds)

Model	Double Acting		Spring Return with S80 Springs	
	Opening Stroke	Closing Stroke	Opening Stroke	Closing Stroke
XL26	0.01	0.01	0.05	0.02
XL71	0.03	0.03	0.09	0.05
XL131	0.03	0.04	0.15	0.09
XL186	0.05	0.06	0.19	0.12
XL221	0.06	0.08	0.24	0.15
XL280	0.20	0.10	0.10	0.20
XL425	0.20	0.30	0.30	0.50
XL680	0.40	0.60	0.40	1.20
XL1125	0.70	0.60	0.50	0.70
XL1370	0.80	0.70	0.70	1.00
XL2582	1.50	1.20	1.20	1.50
XL4580	2.00	2.90	2.20	3.90

Free Air Volume at Atmospheric Pressure XL4580

(Units in Cubic Inches)

Double Acting AND Spring Return

Model	Central Chamber		Displaced Volume
	Open	Closed	
XL26	5.18	1.51	3.67
XL71	13.25	3.92	9.34
XL131	25.90	7.53	18.37
XL186	34.34	10.24	24.09
XL221	45.78	14.76	31.02
XL280	56.56	17.53	39.03
XL425	82.34	20.36	61.98
XL680	122.46	29.94	92.52
XL1125	199.63	50.66	148.97
XL1370	251.13	62.22	188.90
XL2582	453.77	98.19	355.58
XL4580	750.61	125.59	625.02

Spring Return & Double Acting Actuators

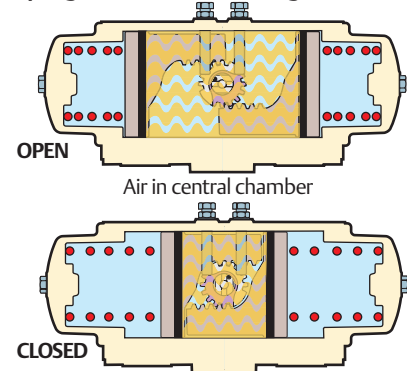

Double Acting ONLY

Model	End Chambers		Displaced Volume
	Open	Closed	
XL26	4.28	7.83	3.55
XL71	12.53	21.69	9.16
XL131	26.32	44.88	18.55
XL186	34.15	58.73	24.58
XL221	47.83	78.73	30.90
XL280	20.00	58.97	38.97
XL425	15.96	73.61	57.65
XL680	35.90	128.18	92.28
XL1125	49.88	196.13	146.26
XL1370	58.79	244.62	185.83
XL2582	74.69	425.15	350.46
XL4580	200.29	820.31	617.01

Double Acting Actuators

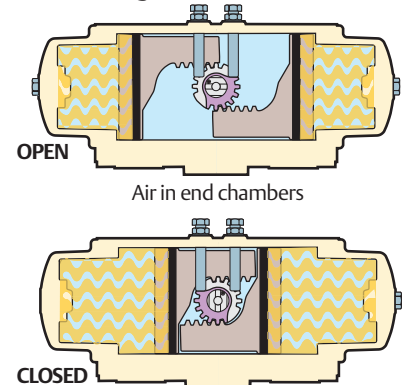



HYTORK products and services

In addition to the XL actuator range Hytork can also offer valve sizing, valve package assembly and engineered solutions to suit all your quarter turn valve automation requirements, available at our Valve Automation Centers.

For details on any of these products and other services please contact HYTORK or your local distributor, or visit our website.



Hytork also manufacture a range of accessories including VDI/VDE engineered accessory mounting kits, switches, solenoid valves, positioners and manual override gearboxes to fit all Hytork actuators.



The XL Series of rack and pinion actuators has twelve (12) sizes in Double acting and Spring return versions with torque outputs up to 35,000 inch.lbs Double acting.



Mounting kits for all types and makes of quarter turn valves are also designed and manufactured by HYTORK.

**Emerson Process Management
Valve Automation Division
Hytork**
6 Bracken Hill
Southwest Industrial Estate
Peterlee, Co. Durham
SR8 2LS
United Kingdom
T: +44 (0191) 518-0020
F: +44 (0191) 518-0032
E: info.Hytork@EmersonProcess.com

**Emerson Process Management
Valve Automation Division
Hytork**
9009 King Palm Drive
Tampa
Florida
33619
United States of America
T: +1 (813) 630-2255
F: +1 (813) 630-9449
E: info.Hytork.USA@EmersonProcess.com

Important:
*Due to Emerson's continuing commitment to engineered product advancement, data presented herein is subject to change. Pictures, schematics and other graphics contained herein are published for illustration purposes only and do not represent product configurations or functionality.
© 2002 Emerson, All rights reserved. All rights to trade marks reside with their respective owners.*

www.hytork.com

