



Valve Monitoring Systems

Bracket Mounted Position Indicator

for Rotary Actuators • Aluminum Body

Features

- Reduced enclosure size with lower profile for use in a wide range of applications.
- Division 2 rated with Viper™ hermetically sealed switches.
- Circular design eliminates pinch points on o-ring seal.
- Internal and external coating for corrosion resistance.
- Realview™ indicator with 100% change in color visible from long distances.

Construction

	VR3	VR2
Area Classifications	Type 4, 4x	Type 4, 4x Div. 2 - Class I, II Groups A,B,C,D, F & G
Switch Type	Mechanical	Viper™
Body	Low Copper Aluminum	
Coating	Black Electrolytic Paint	
Indicator Cover	Polycarbonate	
Shaft	316 Stainless Steel	
Bushings	Bronze (oil lite)	
Hardware	Stainless Steel	

Ambient Temperatures

- 20°F to 170°F (T6)
- 20°F to 180°F (T5)
- 4°F to 140°F with bus card, potentiometer or transmitter

Electrical

VR3 - Mechanical Switches - 15amp silver contacts SPDT, 10amp DPDT contacts

VR2 - Viper™ Switches - Tungsten: 3A/120VAC, 2A/24VDC
Rhodium: 1A/24VDC

Rhodium (IS): 2mA to 1A@24VDC
(suitable for IS applications)

“IS”- Class I,II,III, Div.1
Groups A,B,C,D,E,F and G
Class I, Zone 0, Aex ia IIC T5
Class I, Zone 1, Aex ib IIC T5

12 point terminal strip standard

Viper, Realview - ASCO Valve, Inc. Trademarks



Optional Features

- Low power pilot valve mounted to enclosure
- **AS**™, **DeviceNet**™ communication cards
- 2 (standard) or 3 conduit entries in 3/4” or 20mm
- Plug, cable gland, and network connectors
- Potentiometer and transmitter options
- Alternate indicator color and path options

Specifications

SERIES	SHAFT	CONDUIT	INDICATOR	CHG LTR	SWITCHES	# SW	NETWORK COMMUNICATIONS	CHG LTR
VR2 = Div. 2 Aluminum VR3 = Type 4,4X Aluminum	B = Non NAMUR 316 S.S. C = NAMUR 316 S.S.	2 = (2) 3/4" NPT F 4 = (3) 3/4" NPT F 7 = (2) M20x1.5 F 8 = (3) M20x1.5 F	N = Flat Cover (None) Y = Yellow/Black D = Green/Red R = Red/White G = Green/White B = Blue/White W = Red/Green T = 3Way U = 3Way Divert	A	N = No Switch A = Mech SPDT Silver 15A H = Mech SPDT Gold (IS) D = Mech DPDT 10A T = Viper SPDT Tungsten 3A R = Viper SPDT Rhodium 1A G = Viper SPDT Rhodium (IS) W = Network/Bus Comm. Card	0 1 2 3 4	NG = None RW = RS (0-1000 Ohms) Potentiometer TY = CS (4-20 MA) Transmitter AJ = ASI 2x1, v2.1, 31s STD ADDR AL = ASI 2x1, v2.1, 62s EXT ADDR AK = ASI 4x2, v2.1, 31s STD ADDR AM = ASI 4x2, v2.1, 62s EXT ADDR DC = DNET 2x1 DE = DNET 2x1 Diagnostics DD = DNET 6x2 (M1), 2 out, single acting DH = DNET 6x2 (M2), 1 out, double acting DF = DNET 6x2 DIAG (M1), 2 out, single acting DI = DNET 6x2 DIAG (M2), 1 out, double acting	A

VR2 B 2 Y A T 2 NG A

Ordering Number Example: VR2B2YAT2NGA

Dimensions Inches (mm)

Box with 2 Switches

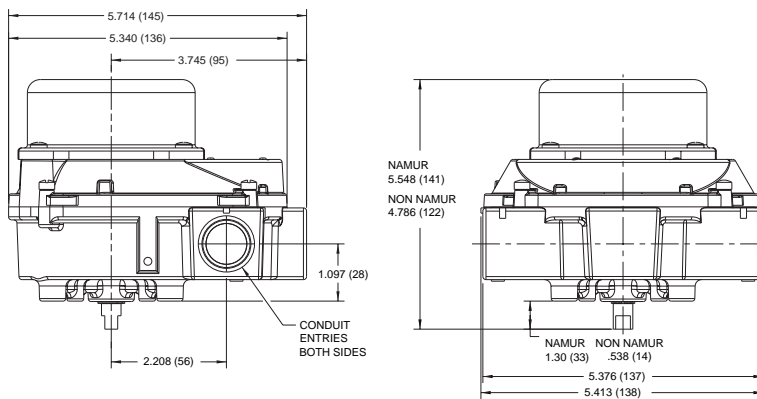

Dimensions for Both

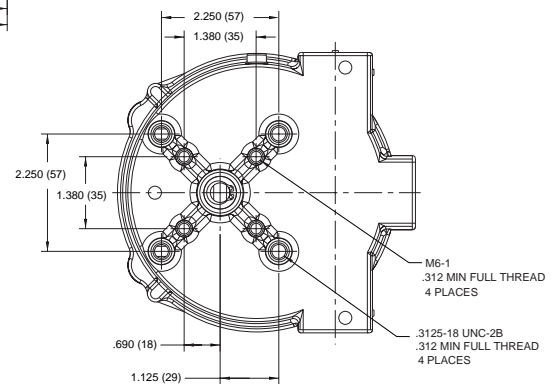

Box with 3 or 4 Switches, Network Card or Transmitter

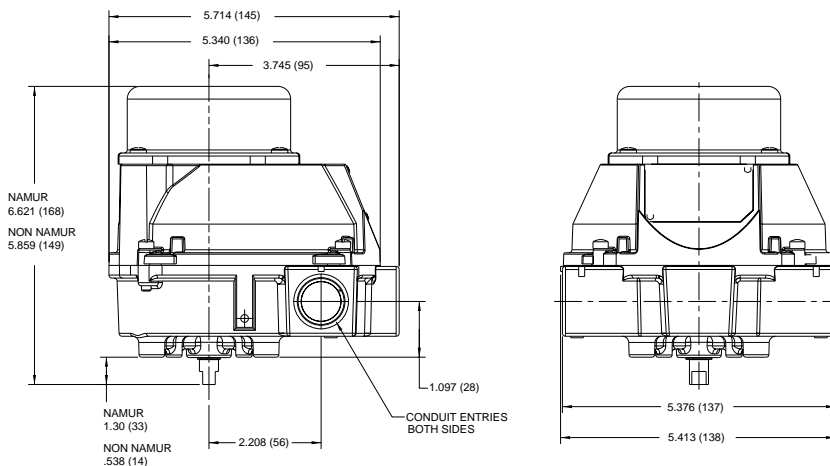

Consult factory for available mounting brackets.