



BETTIS[®]

TorqPlus[™]
Electric Valve
Actuators
and Controls

EMERSON
Process Management

EMERSON. CONSIDER IT SOLVED.™

THE ENGINEERED SOLUTION



Introduction

For more than 40 years, Bettis Corporation has been recognized worldwide for providing industry with high performance pneumatic and hydraulic valve actuators. The addition of the Bettis line of TorqPlus electric actuators carries on the tradition of product quality, innovation and service reliability.

Bettis TorqPlus actuators are specifically designed for quarter-turn operating applications — ball, butterfly and plug valves; dampers; vents and similar uses. TorqPlus actuators are available in a wide range of output torques and operating speeds to fit your specific requirements.

The Bettis Engineered Solution

Most electric actuators in use today are designed to meet a range of torque and speed requirements for use in industrial applications. Controls and optional accessories are often available, added at the factory while being assembled. Heretofore, not much attention has been given to field upgrades, inventory modifications or parts replacement during servicing.

The Bettis TorqPlus actuators, instead, provide its users with a unique modular approach. The actuators are manufactured with pre-tapped holes in the base plate to accommodate a myriad of control and accessory components, available in more than 200 easy-to-install kits to fit virtually every requirement imaginable. Kits are available, depending on the actuator model, to add:

- Heaters and thermostats
- Potentiometers
- Servo controls
- Motor brakes
- Positioners and transmitters
- Control stations
- Multi-turn operation
- PLC interface

All of the components can be added inside the CSA type 4/4x weatherproof housing or the CSA type 4/4x, 7 and 9 weatherproof/explosion proof housings.

Advantages

The Bettis TorqPlus, and the modular concept, offers its users significant advantages:

- **Compact Design** – The actuators provide maximum torque output relative to its small design housing.
- **Custom Control Standards** – By offering an almost endless number of control and accessory combinations, Bettis electric actuators can effectively be designed to virtually any end use.
- **Modular Construction** – The modular design allows the actuators to be easily field modified and serviced. Accessory kits can be stored for future use without consuming a large amount of storage space.
- **High Strength Gearing** – We precision-machine our gears from hardened alloy steel, and run in needle bearings. The result is efficiency, smooth energy transfer, quiet operation and, best of all, long service life.
- **Low Maintenance** – Permanent lubrication reduces the need for scheduled maintenance. The actuators are supplied with low temperature lubricant, allowing the units to perform in temperatures to -40°F (-40°C). All operational parts are fully enclosed in the housing eliminating all contact with the environment.
- **Guaranteed Minimum Torques** – As with other Bettis actuators, we guarantee that our published output torque values are minimum values. If any Bettis TorqPlus actuator fails to meet its specified torque output under normal use, we will replace it.
- **Duty Cycle** – All Bettis actuators are rated for a duty cycle of at least 30% (one motor-on period followed by two motor-off periods). Higher duty cycles (up to 100%), which can allow for up to 1200 starts per hour, at normal ambient temperatures are available.

TYPICAL SPECIFICATIONS

The following information may be used as a guide to compose specifications for Bettis TorqPlus Electric Actuators. Bettis supplies Electric Actuators that meet or exceed all of the specifications stated below except the Model EM-100 (which is not equipped with a manual override feature or dual conduit entrances).

1. General

The actuator shall consist of a sand cast CSA* Certified enclosure complete with an internal high-torque reversible electric motor, terminal block, heat-treated alloy steel gearing, a minimum of two (2) 1/2" NPT conduit connections and a two (2) year original manufacturer's warranty.

2. Actuator Sizing

All actuator torques must be published and must be guaranteed, by the original manufacturer, as minimum values.

The actuator shall be sized to produce a torque equal to or greater than the maximum valve torque, including safety factor, as stated by the valve manufacturer for the service, operating conditions and ambient temperature intended.

3. Ambient Temperature Range

The actuator shall be suitable for normal operation in ambient temperatures ranging from -40 to +140 °F (-40 to +60°C). For temperatures below 32°F (0°C), high-humidity environments or all outdoor applications the actuator shall be supplied with an electric heater and thermostat.

4. Electric Motors

The actuator motor shall be of the reversible, high-torque, open frame ventilated design with built-in automatic resetting thermal overload protection, a minimum 30% duty cycle rating and be UL* and CSA* Certified Motors of 1/4 hp or less with not more than 7 amps of locked rotor current draw. When single phase motors are selected, they shall be supplied as a permanent split capacitor type operating from a 1Ph/60Hz/ 115VAC or 220VAC supply.

5. Reduction Gearing

The actuator shall use exclusively cut alloy gearing. All power gearing shall be grease lubricated for long life.

6. Limit Switches

All limit switches shall be independently operated by adjustable cams in each direction of operation. Provisions shall be made for up to six (6) additional cam operated switches, each being capable of operation at any point of travel.

7. Torque Limit Switches

All actuators of 2,000 lb-in (226 Nm) output torque or greater, shall be supplied with two (2) mechanical torque limiting switches which shall be responsive to maximum torque encountered in both directions of travel.

8. Manual Override

Transfer to manual operation from motor operation shall not require the use of hand levers, solenoid shifters or handwheel depression and the transfer shall be positive and reliable.

Actuators of less than 1700 lb-in, except for the model 100, shall be supplied with a disengageable manual override mechanism. Disengagement of the motor drive shall permit the use of a wrench on the output shaft flats and shall by-pass the power gear drive and motor for manual operation.

Actuators of 2,000 lb-in (226 Nm) or greater output torque shall be supplied with a handwheel which will not rotate during motor operation, but must be operational at all times without danger of injury to operator. The handwheel shall not require more than 50 lbs. of rim force to operate under the most adverse conditions and be capable of assisting or opposing the motor without any form of declutching.

9. Enclosure

The actuator enclosure shall be a high-strength sand casting and must be certified by CSA*, or equal third party tester, as acceptable for use in the following locations:

- 9.1 Non-hazardous indoor or outdoor location to protect against wind-blown dust and rain, splashing water and hose-directed water (i.e. CSA Enclosure 4 – Weatherproof, conforms to IP-65).
- 9.2 Hazardous locations classified as Class I and II, Groups C, D, E, F and G as defined in the National Electrical Code **plus** non-hazardous locations to protect against wind-blown dust and rain, splashing water and hose-directed water (i.e. CSA Enclosure 4 and 7 – Explosion-proof and Weatherproof).

*CSA is Canadian Standards Associations, Rexdale Ontario, Canada M9W 1R3

*UL is Underwriters Laboratories, Inc., Northbrook, IL 60062

*NEMA is National Electrical Manufacturers Association, Washington, D.C. 20037

DESIGN AND CONSTRUCTION

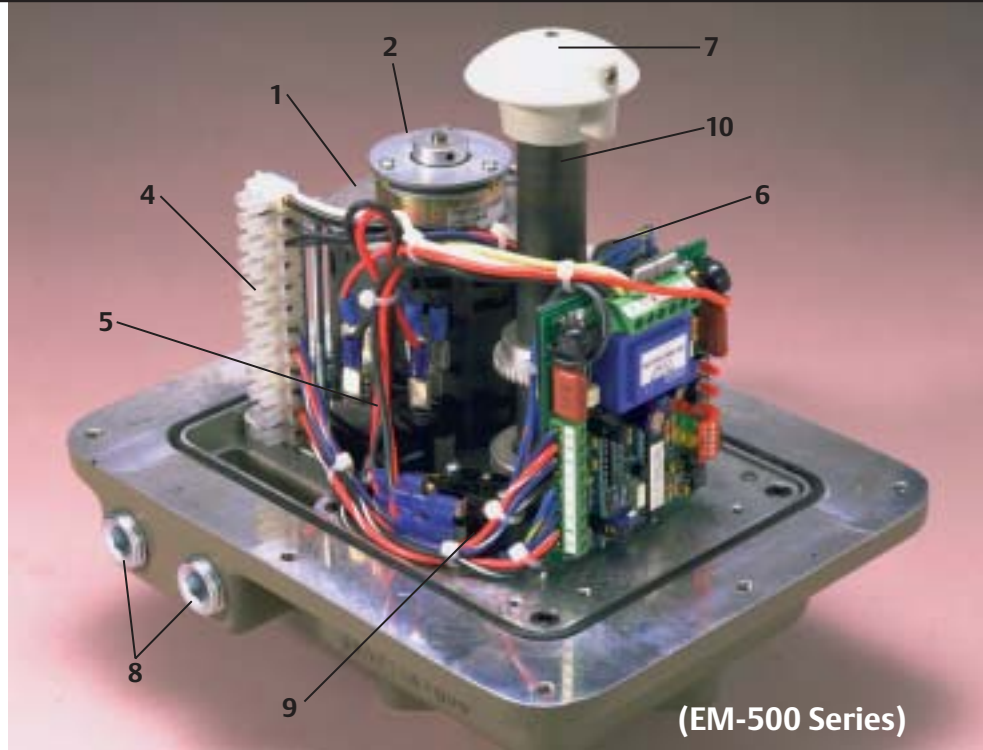

These very rugged and versatile electric actuators take full benefit of precision-machining which allows every model to provide maximum torque output relative to its compact design configuration and contains a minimum of parts to reduce vibration, lessen noise and resist harsh service. Utilizing a combination of spur, worm and planetary power gearing reduction systems, the Bettis TorqPlus actuators incorporate the most efficient, powerful and appropriate drive design for service excellence.

1. Motors. Available in Single Phase, 3 Phase and DC voltages, all motors are custom built for high-torque, low current draw and the highest duty cycle ratings offered. Single phase motors are capacitor run type and three phase are squirrel cage induction type both having integral self resetting thermal cut-outs.

2. Brakes. Offered for all AC and DC motors, they are capable of a holding force equal to the output torque ratings of each actuator model.

3. Heater and Thermostat. Securely mounted and appropriately sized to insure ample protection even in the worst environments (not visible in photo).

4. Terminal Strips. Standard in all models and allow

easy plus efficient actuator installation.

5. Capacitors. Used on all single phase AC units, each capacitor is peak voltage rated and of improved design for maximum service life.

6. Potentiometers. Precision mechanically linked to actuator output drive for continuous position signaling.

7. Position Indicator. Mechanically driven and easily viewed at top of actuator to insure or confirm actual actuator and driven device position at all times (not available on compact Model EM-100).

8. Dual Conduit Connections. Standard on all models, except EM-100, allows full electrical code access of all wiring through two NPT connections.

9. Torque Limit Switches. Standard for the high-torque 800-Series of Bettis TorqPlus actuators. These mechanical switches eliminate potential driven device damage due to over torque conditions in either direction of operation.

10. Manual Override. Standard in all models except the EM-100, manual override capability is offered in two forms; Declutchable and Direct Acting.

DESIGN AND CONSTRUCTION

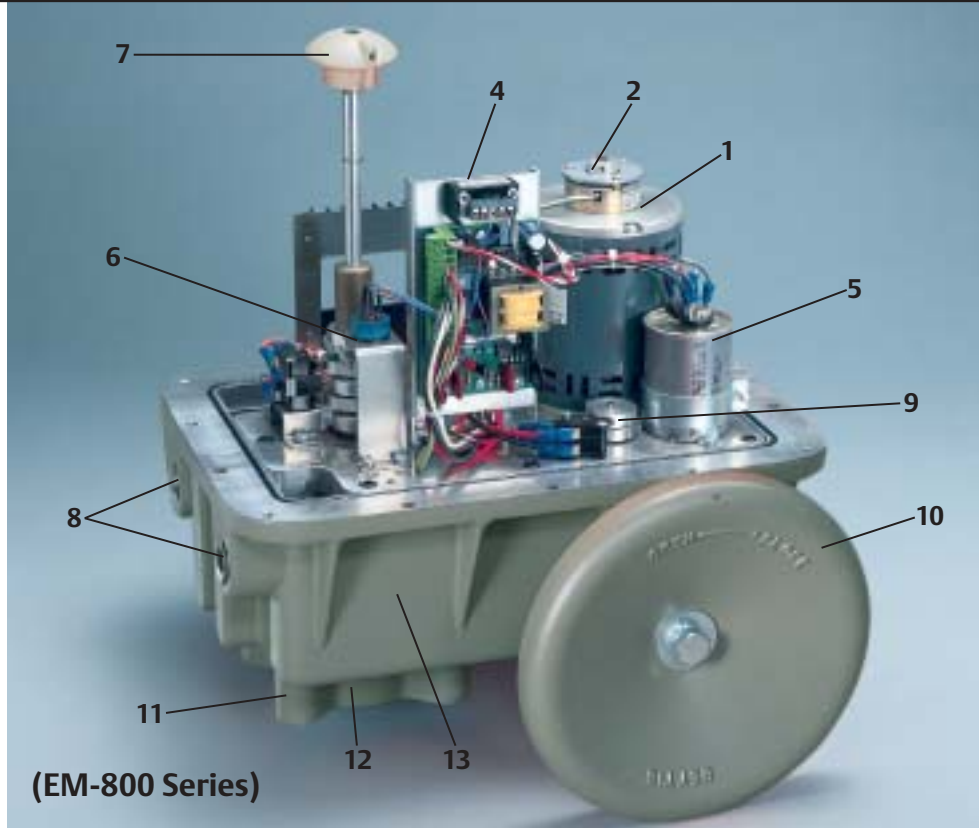

Model EM-300 and the complete 500-Series offer a Declutchable design which disengages the power gear drive from the output shaft. Manual operation is accomplished by rotating the exposed output shaft drive flats with an open end wrench after the position indicator knob is pulled up. Return to full automatic operation is as easy as removing the wrench and lowering the position indicator knob to allow the mechanism to re-engage upon application of power. Should power be applied during manual operation, the declutchable design will not allow the output shaft to rotate.

The 800-Series offers a Direct Acting handwheel design which allows completely safe operation at any time and with never more than 50 pounds of rim pull force. Operating independent of the motor but directly into the power gear drive, the handwheel does not rotate during automatic operation of the actuator, requires no engagement action for manual operation and may be rotated with or without power to the unit.

11. Enclosures. Made from high strength sand castings, enclosures are rated for applications in both Non-hazardous and Hazardous locations. As an option, the Bettis TorqPlus is also available with a CSA Certified combination Hazardous and Non-hazardous enclosure for indoor and outdoor protection in locations classified Class I and II, Groups C, D, E, F and G as defined in the National Electrical Code plus protects against wind-blown dust, wind-blown rain, splashing water and hose-directed water.

12. Output Drives are corrosion resistant. Female drives are available in a variety of DIN/ISO 8-point sizes. Male drives are also available on models 300 and 500. The EM-800 series is provided with bored drive sleeve with double keyways.

13. Powder Coat Finish. A polyester external coating developed to serve as both a high durability impact and chemical resistant finish. With up to 160 lb-in ASTM D2794 impact resistance, over 1000 hours ASTM B117 salt spray rating and 1000+ hours ASTM D2247 humidity resistance, this protective finish will stay in place and do the job.



Torque 100 IN/LB – 350 IN/LB

The Engineered Solution

Bettis TorqPlus quality line of electric actuators are designed for quarter turn applications — ball, butterfly and plug valves; dampers; vents and similar uses. TorqPlus actuators are manufactured in a wide range of **guaranteed** output torques and operating speeds to fit your specific requirements.

The Model EM-100 actuators offer compactness with a rugged design to develop maximum torque in a small package.



- Single phase capacitor run motor with thermal overload protection and internal motor brake for 250 in/lb and 350 in/lb models
- Enclosure certified to weatherproof C.S.A. specifications that conform to Nema type 1, 2, 3, 3R, 4, 4X, & 12
- Two single pole double throw travel-stop limit switches with adjustable cams
- Female DIN/ISO output drive sleeve and DIN/ISO bolt pattern
- Operational in any mounting orientation
- Weight: 5 lbs
- Single 1/2-inch NPT conduit entrance

OPTIONAL FEATURES

- Maximum of two additional single pole double throw auxiliary limit switches
- Heater and thermostat
- Canadian Standards Association general purpose for electrical certification available under file #LR90062
- Standard 1KΩ potentiometer. Other ranges provided upon request.
- Relay control
- Electronic proportional positioner for 4-20 mA, 1-5 VDC, or 0-10 VDC control input and 4-20mA output signal
- Optional voltages
 - 230 VAC 50/60 Hz single phase
 - 12/24 VDC
 - 24 VAC

STANDARD FEATURES

- Two year warranty
- Permanently lubricated gear train
- Stainless steel output drive sleeve
- Operating temperatures:
 - 40°F with heater activated, to +140° F
- Unidirectional motor with thermal overload protection and mechanical brake for 100 in/lb model



Torque 100 IN/LB – 350 IN/LB

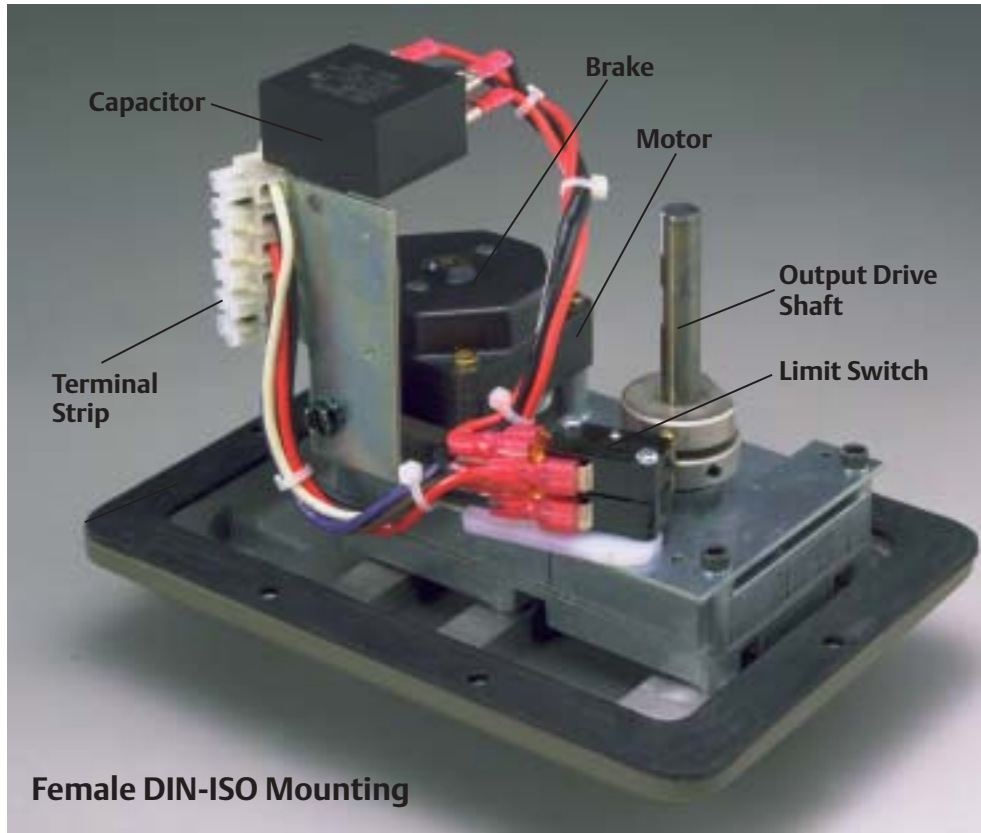

MODEL EM-100 SERIES								
TORQUE		SPEED 90°	LOCKED ROTOR AMP				MOTOR DUTY CYCLE @ 75°F	
IN/LB	NM		115VAC	220VAC	12VDC	24VDC	AC	DC
100	11	2 SEC	1.30	CF*	N/A	N/A	30%	N/A
250	28	10 SEC	0.70	CF*	.70	1.40	30%	100%
350	39	13 SEC	0.70	CF*	N/A	N/A	30%	N/A

* Consult factory for 230VAC locked rotor current.

Model #	Mounting Bolt Circle	Drive Sleeve
133	F03	F03
144	F04	F04
155	F05	F05

Bettis Electric
 2500 Park Avenue West
 Mansfield, OH 44906 U.S.A.
 T 419-529-4296
 F 419-529-4484
 Website: www.EmersonProcess.com/Bettis
 E-Mail: Info.Bettis.Electric@EmersonProcess.com



Torque 150 IN/LB – 600 IN/LB

The Engineered Solution

Bettis TorqPlus quality line of electric actuators are designed for quarter turn applications — ball, butterfly and plug valves; dampers; vents and similar uses. TorqPlus actuators are manufactured in a wide range of **guaranteed** output torques and operating speeds to fit your specific requirements.

The Model EM-300 actuators combine compactness with manual override capability and an extensive array of available options for a broad spectrum of applications.



STANDARD FEATURES

- Two year warranty
- Heater and thermostat installed in all actuators
- Case hardened steel spur gear train is permanently lubricated
- Hardened steel drive shaft
- Female DIN/ISO F04 output drive and bolt pattern or male output drive

- Operating temperatures:
 - 40° F with standard heater activated to +140° F
- Single phase capacitor run motor with thermal overload protection
- Internal motor brake on 4 and 10 second units
- Enclosure certified to weatherproof C.S.A. specifications that conform to NEMA type 1, 2, 3, 3R, 4, 4X & 12
- Two single pole double throw travel-stop limit switches with adjustable cams
- Declutchable manual override with position indicator
- Dual 1/2-inch NPT conduit entrance
- Operational in any mounting orientation.
- Weight: 11 to 12 lbs

OPTIONAL FEATURES

- 75% or 100% extended duty cycle motors
- Electromechanical brake for 15 second and 30 second units
- Standard 1KΩ potentiometer. Other ranges provided upon request.
- Relay control
- Electronic proportional positioner for 4-20 mA, 1-5 VDC, or 0-10 VDC control input and 4-20mA output signal
- Optional voltages
 - 230 VAC 50/60 Hz single phase
 - 12/24 VDC
 - 24 VAC
- Maximum of four additional auxiliary single pole double throw auxiliary limit switches with adjustable cams.
- Handwheel
- Canadian Standards Association general purpose for electrical certification available under file #LR90062
- Dual purpose weatherproof and explosion-proof enclosures are certified by Canadian Standards Association for services: Class I Groups C,D, Division I; Class II Groups E,F,G Division I that conform to NEMA type 7 and 9



Torque 150 IN/LB – 600 IN/LB

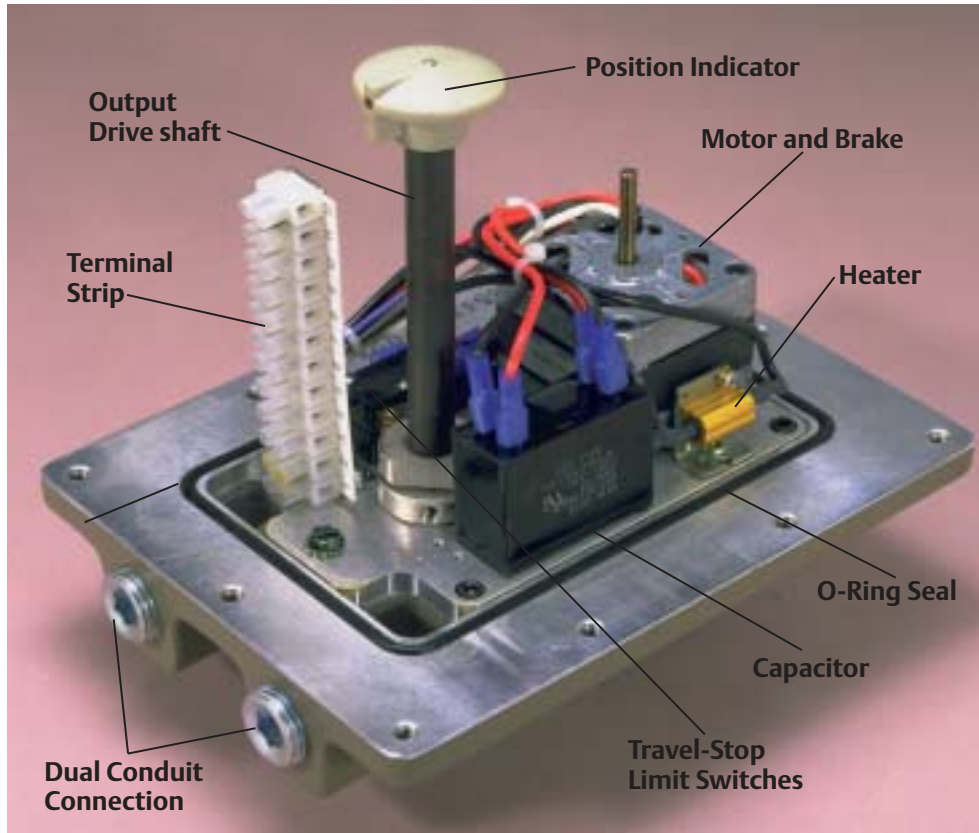

MODEL EM-300 SERIES									
TORQUE		SPEED 90°	MODEL	LOCKED ROTOR AMP				MOTOR DUTY CYCLE @ 75°F	
IN/LB	NM			115VAC	230VAC	12VDC	24VDC	AC	DC
150	17	4 SEC	300-04	0.57 *	0.29	1.2A	2.5A	**30%	100%
300	34	10 SEC	300-10	0.57 *	0.29	1.2A	2.5A	**30%	100%
400	45	15 SEC	300-15	0.56 *	0.25	1.2A	2.5A	**30%	100%
600	68	30 SEC	300-30	0.56 *	0.25	1.2A	2.5A	**30%	100%

* Locked rotor current for all 75% and 100% duty cycle motors is 0.50 amp

**75% and 100% duty cycle motors are available for 115 VAC service

Bettis Electric
 2500 Park Avenue West
 Mansfield, OH 44906 U.S.A.
 T 419-529-4296
 F 419-529-4484
 Website: www.EmersonProcess.com/Bettis
 E-Mail: Info.Bettis.Electric@EmersonProcess.com

Torque 350 IN/LB – 1600 IN/LB

The Engineered Solution

Bettis TorqPlus quality line of electric actuators are designed for quarter turn applications — ball, butterfly and plug valves; dampers; vents and similar uses. TorqPlus actuators are manufactured in a wide range of **guaranteed** output torques and operating speeds to fit your specific requirements.

The Model EM-500 Series are designed for the entire mid-range of torques and operating speeds, with a rugged versatility that is hard to beat.



STANDARD FEATURES

- Two year warranty
- Heater and thermostat installed in all actuators
- Hardened steel spur gear train is permanently lubricated
- Hardened steel drive shaft
- Female DIN/ISO F07 output drive and F07/F10 bolt pattern or male output drive

- Operating temperatures:
 - 40° F with standard heater activated, to +140° F
- Single phase capacitor run motor with thermal overload protection
- Enclosure certified to weatherproof C.S.A. specifications that conform to NEMA type 1, 2, 3, 3R, 4, 4X and 12
- Declutchable manual override with position indicator
- Dual 1/2-inch NPT machined conduit entrances
- Captive hex bolts on enclosure
- Operational in any mounting orientation
- Two single pole double throw end of travel stop limit switches with adjustable cams
- Weight: 17 to 18 lbs

OPTIONAL FEATURES

- Electromechanical brake
- Standard 1K Ω potentiometer, other ranges provided upon request
- Electronic proportional positioner for 4-20mA, 1-5 VDC, or 0-10 VDC control input, and 4-20mA output signal
- Relay control
- Optional voltages
 - 220 VAC 50/60 Hz single phase
 - 12/24 VDC
 - 24 VAC
- Maximum of four additional single pole double throw auxiliary limit switches with adjustable cams
- Handwheel
- Dual purpose weatherproof and explosion-proof enclosures are certified by Canadian Standards Association for services: Class I Groups C,D, Division I; Class II Groups E,F,G Division I that conform to NEMA type 7 and 9
- Canadian Standards Association general purpose for electrical certification available under file #LR90062



Torque 350 IN/LB – 1600 IN/LB

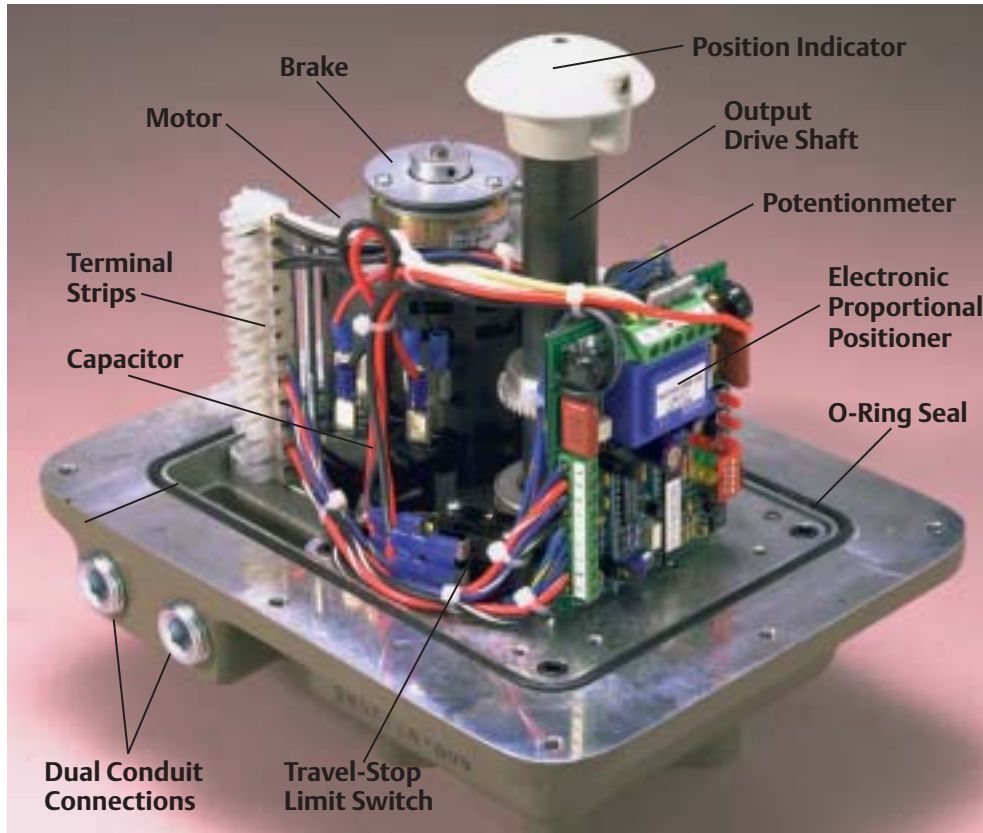

*Heater and Thermostat not shown.

MODEL EM-500 SERIES									
TORQUE		SPEED 90°	MODEL	LOCKED ROTOR AMP				MOTOR DUTY CYCLE @ 75°F	
IN/IB	NM			115VAC	230VAC	12VDC	24VDC	AC	DC
350	39	5 SEC	500-05	0.69	0.36	4.3	5.0	100%	100%
700	79	10 SEC	500-10	0.69	0.36	4.3	5.0	100%	100%
1000	113	15 SEC	500-15	0.69	0.36	4.3	5.0	100%	100%
1600	181	30 SEC	500-30	0.35	0.45	4.3	5.0	100%	100%
325	36	2 SEC	510-02	1.57	0.80	4.3	8.5	100%	100%
600	68	5 SEC	510-05	1.57	0.80	4.3	8.5	100%	100%
1000	113	7 SEC	510-07	1.57	0.80	4.3	8.5	100%	100%
180	20	5 SEC	520-05	0.57	0.29	1.2	2.5	30%	100%
450	51	10 SEC	520-10	0.57	0.29	1.2	2.5	30%	100%
600	68	15 SEC	520-15	0.57	0.29	1.2	2.5	30%	100%
1000	113	30 SEC	520-30	0.57	0.29	1.2	2.5	30%	100%

Bettis Electric Mansfield, OH U.S.A. T 419-529-4296 Website: www.EmersonProcess.com/Bettis



Torque 2,000 IN/LB – 20,000 IN/LB

The Engineered Solution

Bettis TorqPlus quality line of electric actuators are designed for quarter turn applications — ball, butterfly and plug valves; dampers; vents and similar uses. TorqPlus actuators are manufactured in a wide range of **guaranteed** output torques and operating speeds to fit your specific requirements.

The EM-800 Series utilizes a highly effective planetary gearing system and a handwheel manual override to produce maximum torques in a compact package.



STANDARD FEATURES

- Two year warranty
- Heater and thermostat installed in all actuators
- Case hardened steel spur gear train is permanently lubricated
- Operating temperatures:
 - 40° F with standard heater activated, to +140° F
- Single phase capacitor run motor with thermal overload protection

- Enclosure certified to weatherproof C.S.A. specifications that conform to NEMA type 1, 2, 3,3R, 4 and 12
- Handwheel manual operation
- Mechanical position indicator
- Captive hex bolts on enclosure
- Dual 3/4-inch NPT machined conduit entrances
- Two single pole double throw travel-stop limit switches with adjustable cams and 2 aux S.P.D.T.
- Female drive
- Weight: 65-70 lbs (type 4), 150-160 lbs (explosion-proof)
- Two mechanical torque limit switches

OPTIONAL FEATURES

- Dual purpose weatherproof and explosion-proof enclosures are certified by Canadian Standards Association for services: Class I Groups C,D, Division I; Class II Groups E,F,G Division I that conform to NEMA type 7 and 9
- Standard 1K potentiometer, other ranges provided upon request
- Electronic proportional positioner for 4-20 mA, 1-5 vDC, or 0-10 vDC control input and 4-20mA output signal
- Optional voltages
 - 220 VAC 50/60 Hz single phase
 - 220 VAC 50/60 Hz 3 phase
- Relay control
- Maximum of four additional single pole double throw auxiliary limit switches with adjustable cams
- Electromechanical brake
- Canadian Standards Association general purpose for electrical certification available under file #LR90062



Torque 2,000 IN/LB – 20,000 IN/LB

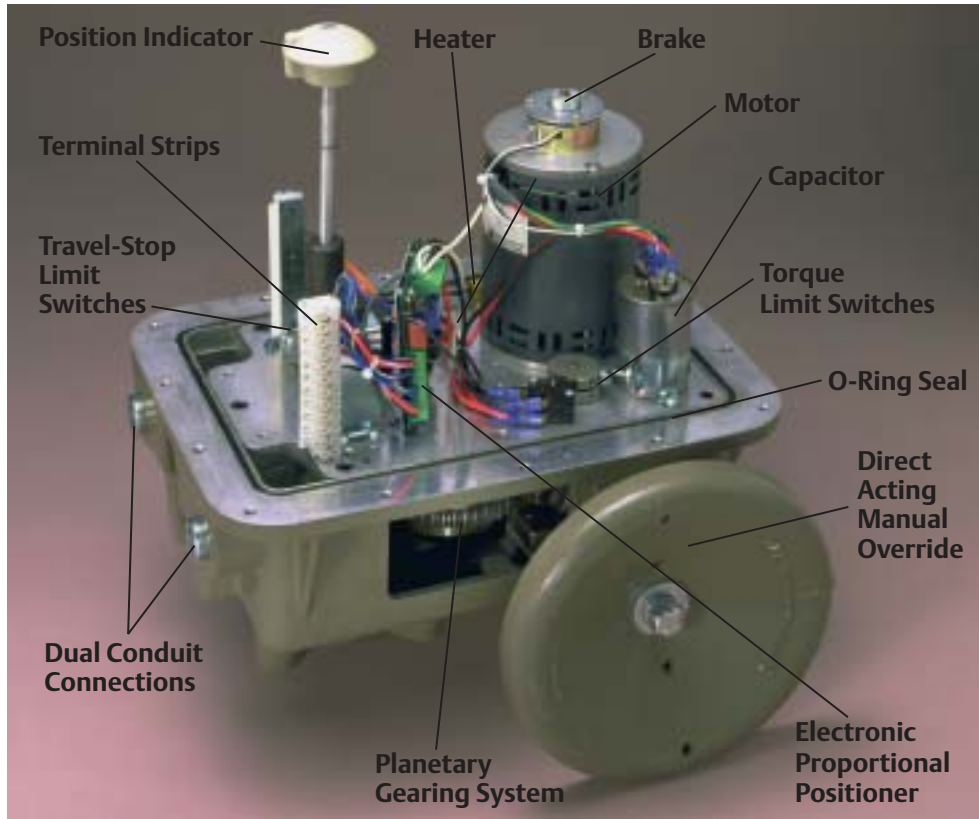

MODEL EM-800 SERIES						
TORQUE		SPEED 90°	MODEL	LOCKED ROTOR AMP		MOTOR DUTY CYCLE @ 75°F
IN/LB	NM			115VAC	230VAC	
2000	226	12 SEC	810-12	3.15	1.3	100%
2500	282	18 SEC	810-18	3.15	1.3	100%
3500	395	30 SEC	810-30	3.15	1.3	100%
4000	452	60 SEC	810-60	3.15	1.3	100%
3000	338	12 SEC	820-12	3.15	1.3	100%
4000	452	18 SEC	820-18	3.15	1.3	100%
6000	678	30 SEC	820-30	3.15	1.3	100%
7000	791	60 SEC	820-60	3.15	1.3	100%
5000	565	12 SEC	830-12	5.97	2.81	100%
7000	791	18 SEC	830-18	5.97	2.81	100%
10000	1130	30 SEC	830-30	5.97	2.81	100%
10000	1130	60 SEC	830-60	5.97	2.81	100%
15000	1695	48 SEC	840-48	5.97	2.81	100%
20000	2260	72 SEC	840-72	5.97	2.81	100%



Torque 300 IN/LB – 1,600 IN/LB

The Engineered Solution

Bettis TorqPlus has taken the lead in offering compact, cost effective Spring Return Electric Actuator Packages. Three models offer a variety of solutions when one needs to protect a system upon loss of power. These actuators have been designed for dampers, small butterfly, ball and plug valves.



The Model EM-SR5 Series is designed for use in environments where automatic closing/opening is required upon loss of power, with a rugged versatility that is hard to beat.

When power is available, the device operates like a normal quarter turn, open/close or modulating actuator. Under powered operation, the spring pack travels with the movement of the actuator. Under powered stopped conditions, the actuator and spring are held in position via the electric mechanical brake. Upon loss of power, the spring is released and drives the actuator to the predesignated failsafe position. The failsafe positioning can be provided for either the CCW limit or to the CW limit.

STANDARD FEATURES

- Two year warranty
- Heater and thermostat
- Case hardened steel spur gear train is permanently lubricated
- Operating temperatures: -40° F, with standard heater activated, to +140° F
- Thermally protected permanent split capacitor motor
- Electromechanical brake
- CW or CCW spring return
- Dual 1/2-inch NPT conduit entrances
- Captive hex bolts on enclosure
- Operational in any mounting orientation
- Limit switches with independent end of travel cams
- Male output drive on all models or female DIN/ISO F04 or F05 output drive on 10, 15 and 30 second models
- Adjustable mechanical stop at the fail safe position
- Visual position indicator
- Enclosure certified to weatherproof C.S.A. specifications that conform to NEMA type 1, 2, 3, 3R, 4, 4X and 12

OPTIONAL FEATURES

- Modulating service (separate enclosure)
- Standard 1KΩ potentiometer, other ranges provided upon request
- Optional 220 VAC 50/60 Hz motor
- Up to four auxiliary switches with adjustable cams
- Canadian Standard Association general purpose for electrical certification available under file #LR90062
- Dual purpose weatherproof and explosion-proof enclosures are certified by Canadian Standards Association for services: Class I Groups C,D, Division I; Class II Groups E,F,G Division I that conform to NEMA type 7 and 9

MODEL EM-SR5 SERIES										
Model	Torque (against spring)		Torque (with spring)		Speed (sec/90°)		Motor Ratings			Weight (lbs)
	in/lb	nm	in/lb	nm	Motor	Spring	LRA	FLA	Duty Cycle	
SR5-10	300	34	350	40	10	4	0.69	0.34	100%	28-30
SR5-15	400	45	450	51	15	5	0.69	0.34	100%	28-30
SR5-30	600	68	700	79	30	6	0.35	0.30	100%	36-38
SR5-90	1600	181	1400	158	90	25	0.35	0.30	100%	138



Torque 300 IN/LB – 1,400 IN/LB

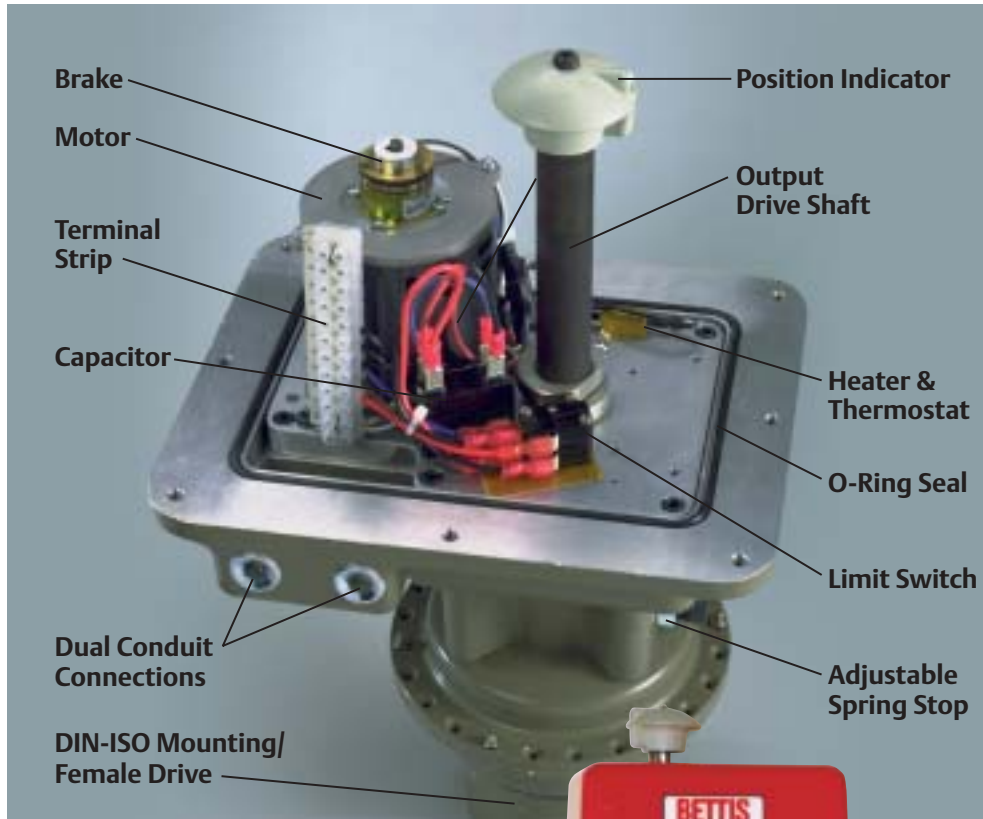

EM-SR5-90 with
Gear Reduction Box

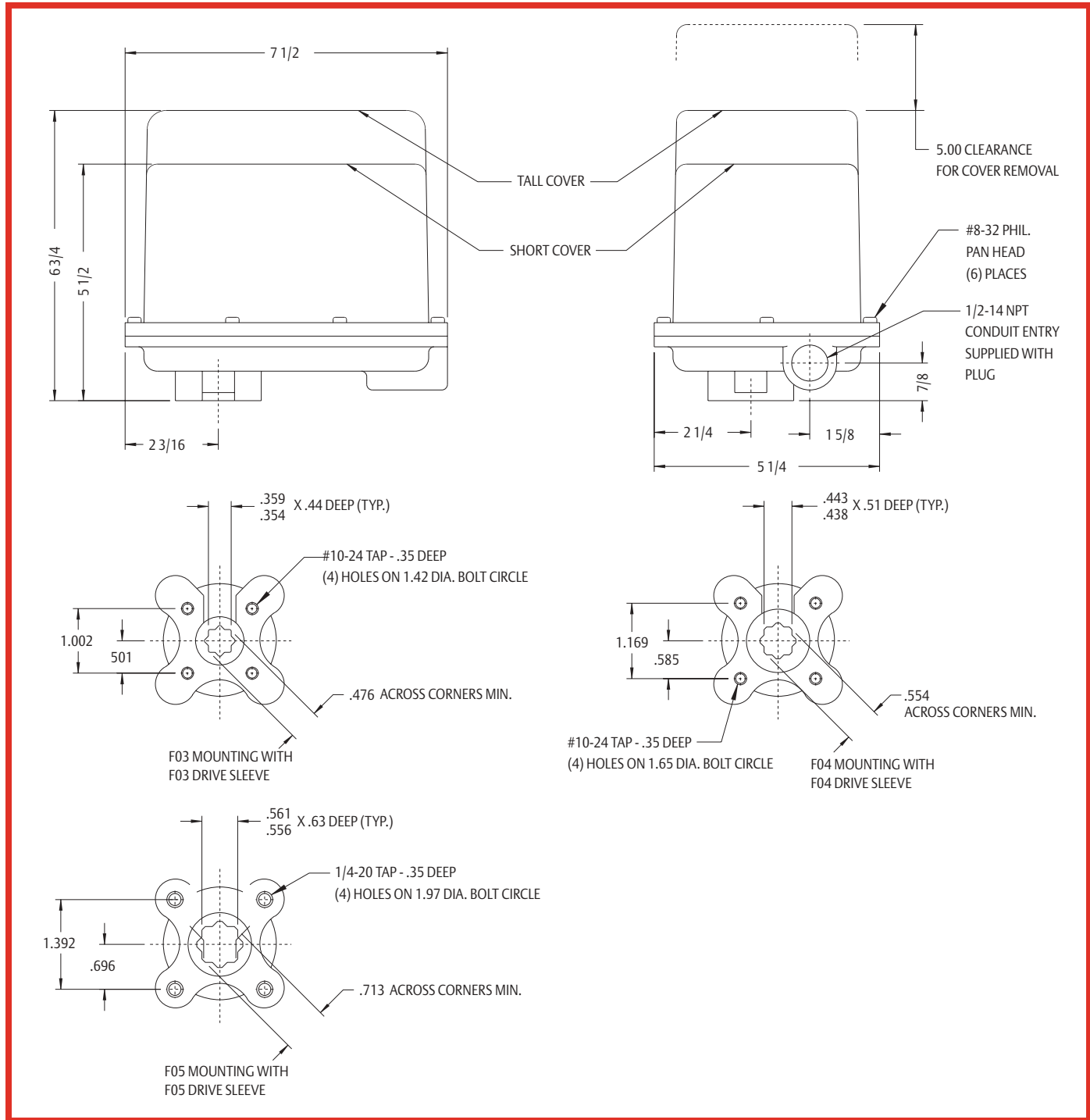

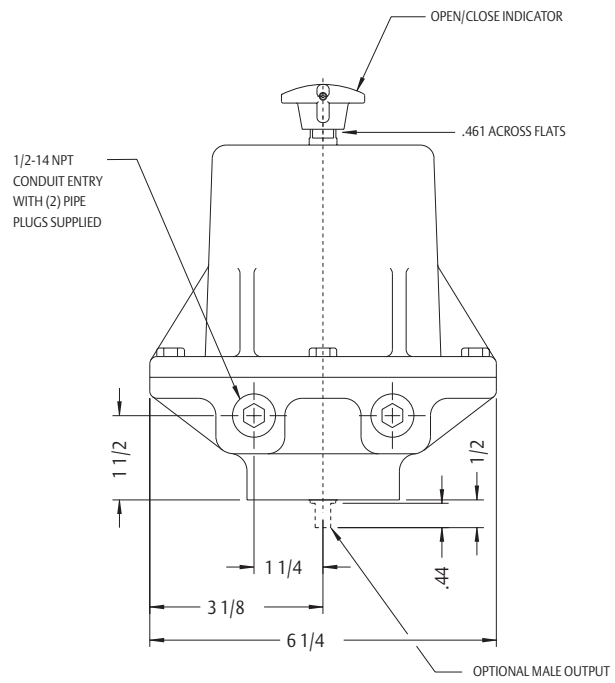
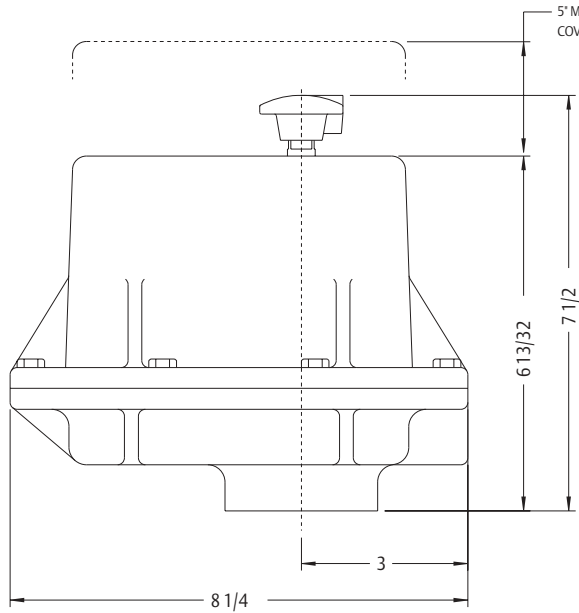

DIN/ISO F04 FLANGE
F04 DIN/ISO FEMALE DRIVE

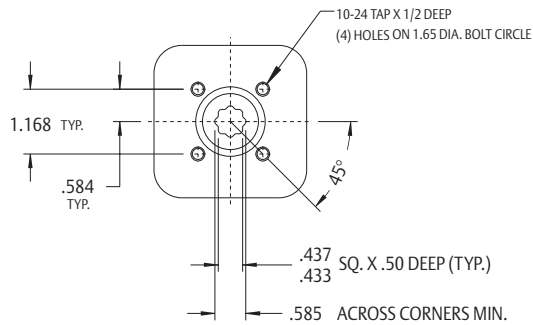

FLANGE DIMENSIONS
WITH MALE OUTPUT

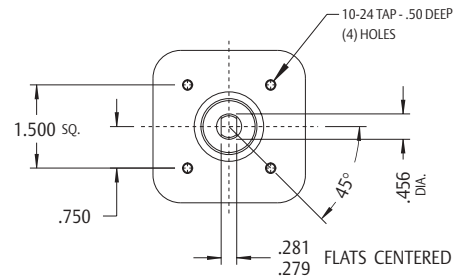

Bettis Electric

2500 Park Avenue West, Mansfield, OH 44906 U.S.A. T 419-529-4296 F 419-529-4484
Website: www.EmersonProcess.com/Bettis E-Mail: Info.Bettis.Electric@EmersonProcess.com

Assembly Layout Drawings



MODEL EM-500 EM-510 EM-520

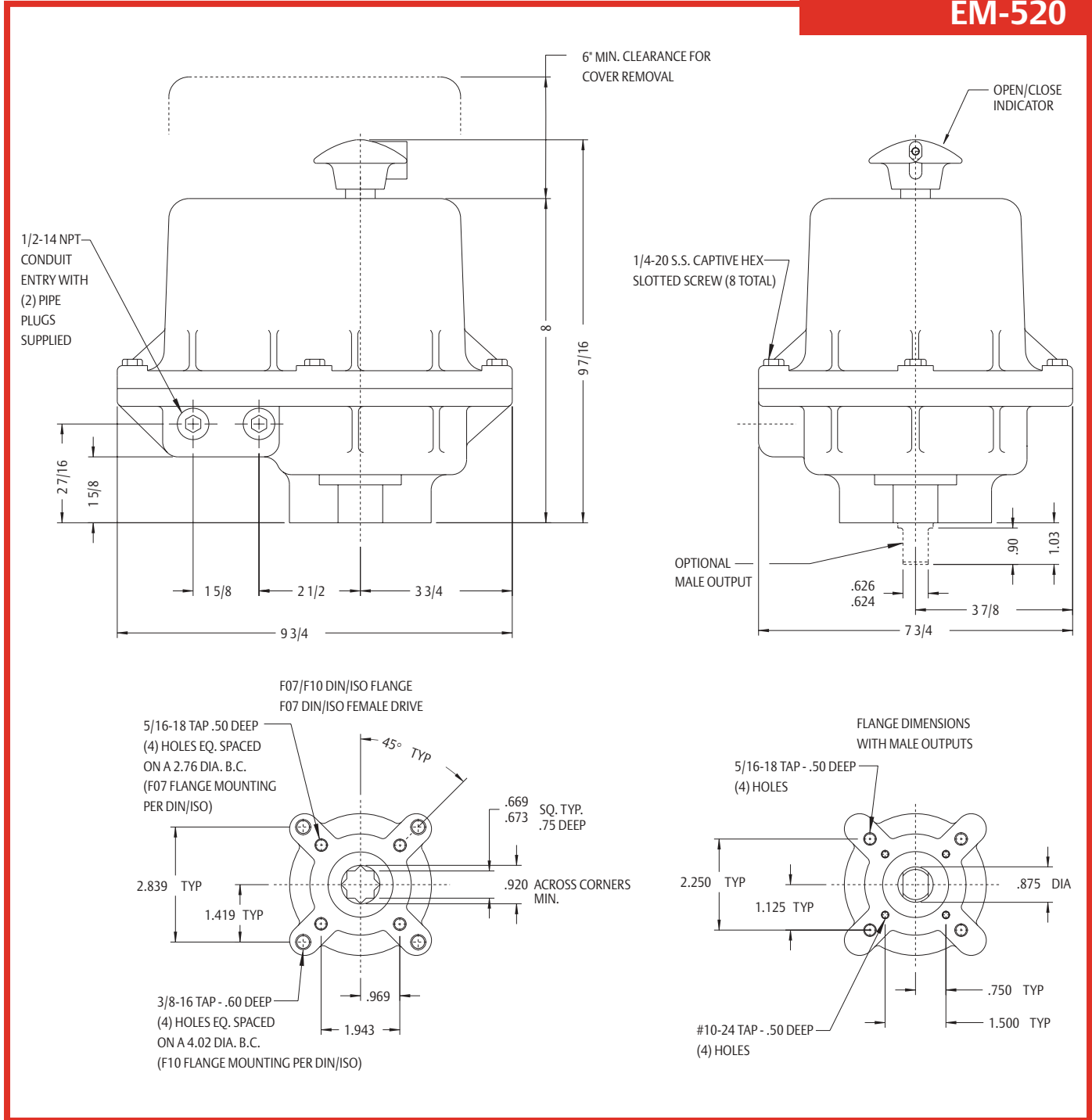

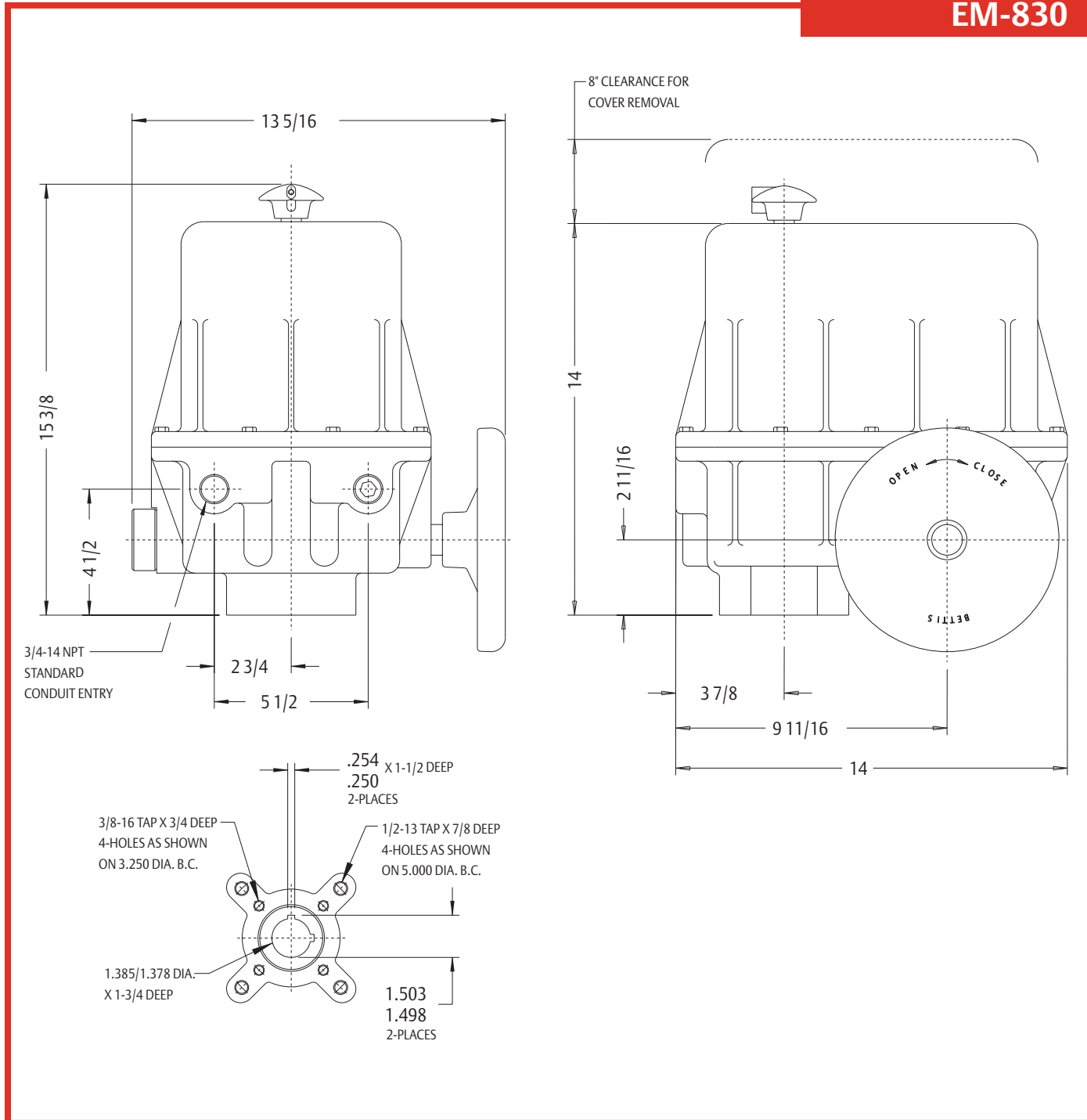

Bettis Electric
 2500 Park Avenue West, Mansfield, OH 44906 U.S.A. T 419-529-4296 F 419-529-4484
 Website: www.EmersonProcess.com/Bettis E-Mail: Info.Bettis.Electric@EmersonProcess.com

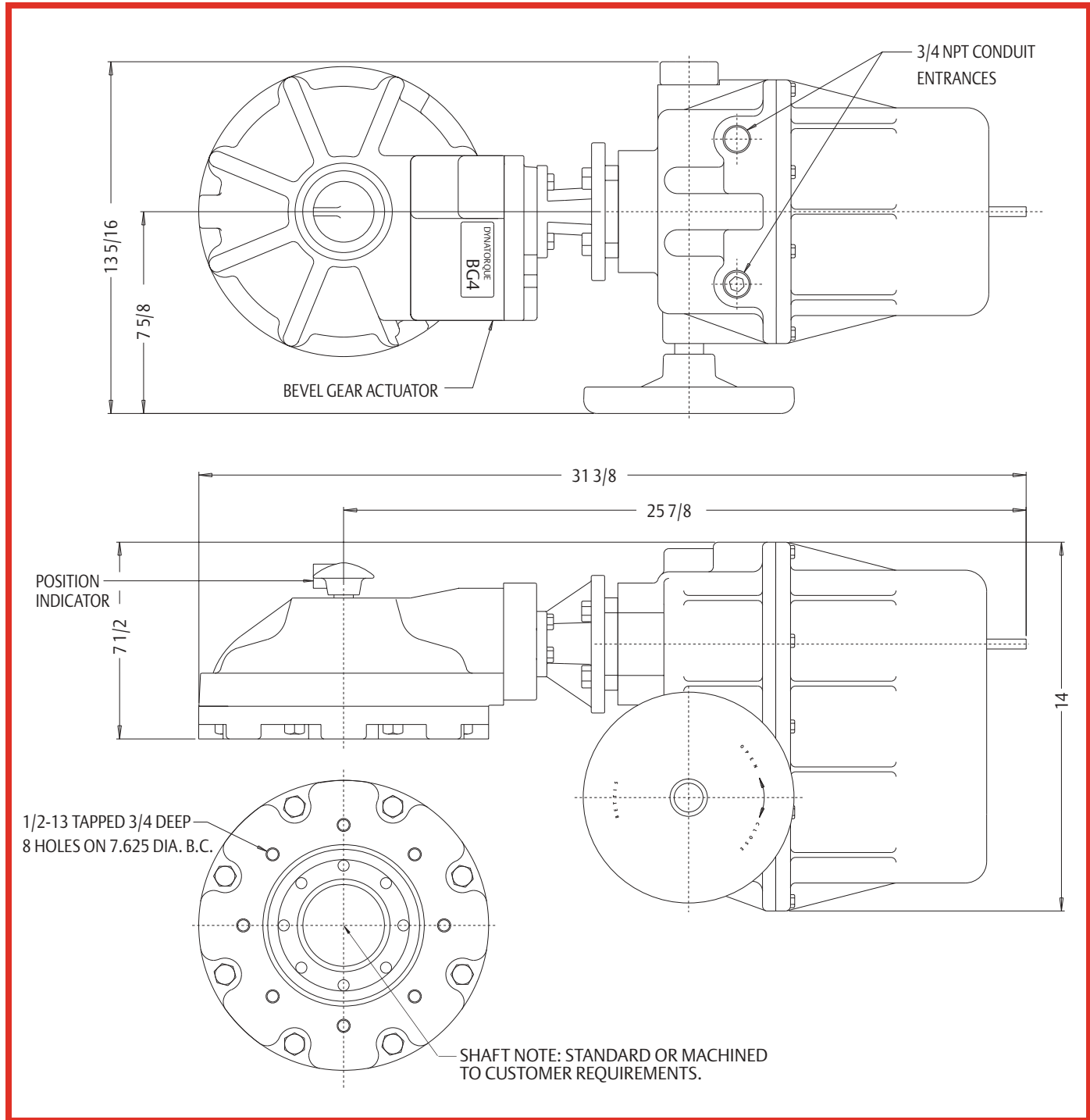

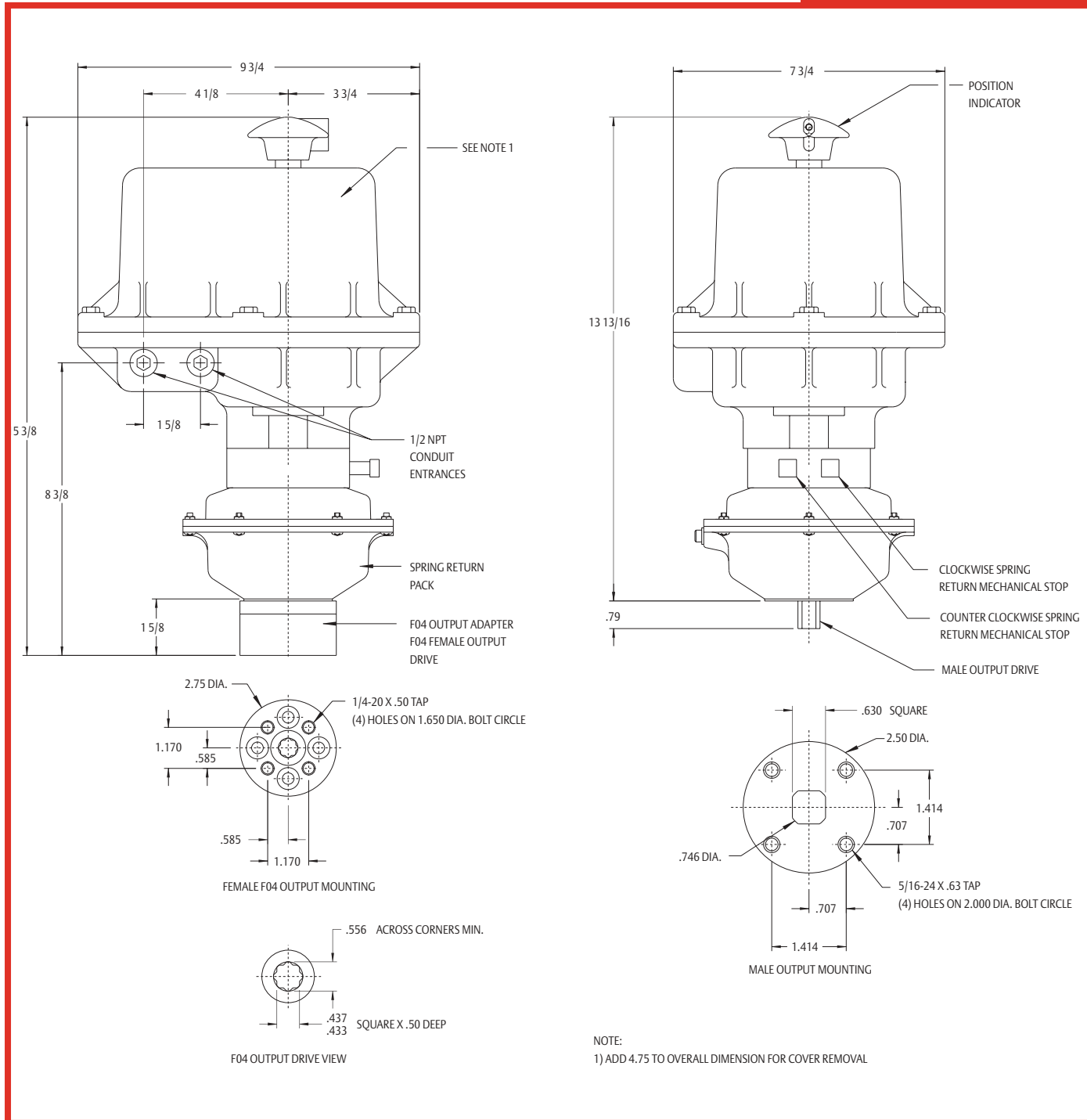

Bettis Electric
 2500 Park Avenue West, Mansfield, OH 44906 U.S.A. T 419-529-4296 F 419-529-4484
 Website: www.EmersonProcess.com/Bettis E-Mail: Info.Bettis.Electric@EmersonProcess.com

Assembly Layout Drawings



MODEL EM-SR5-30

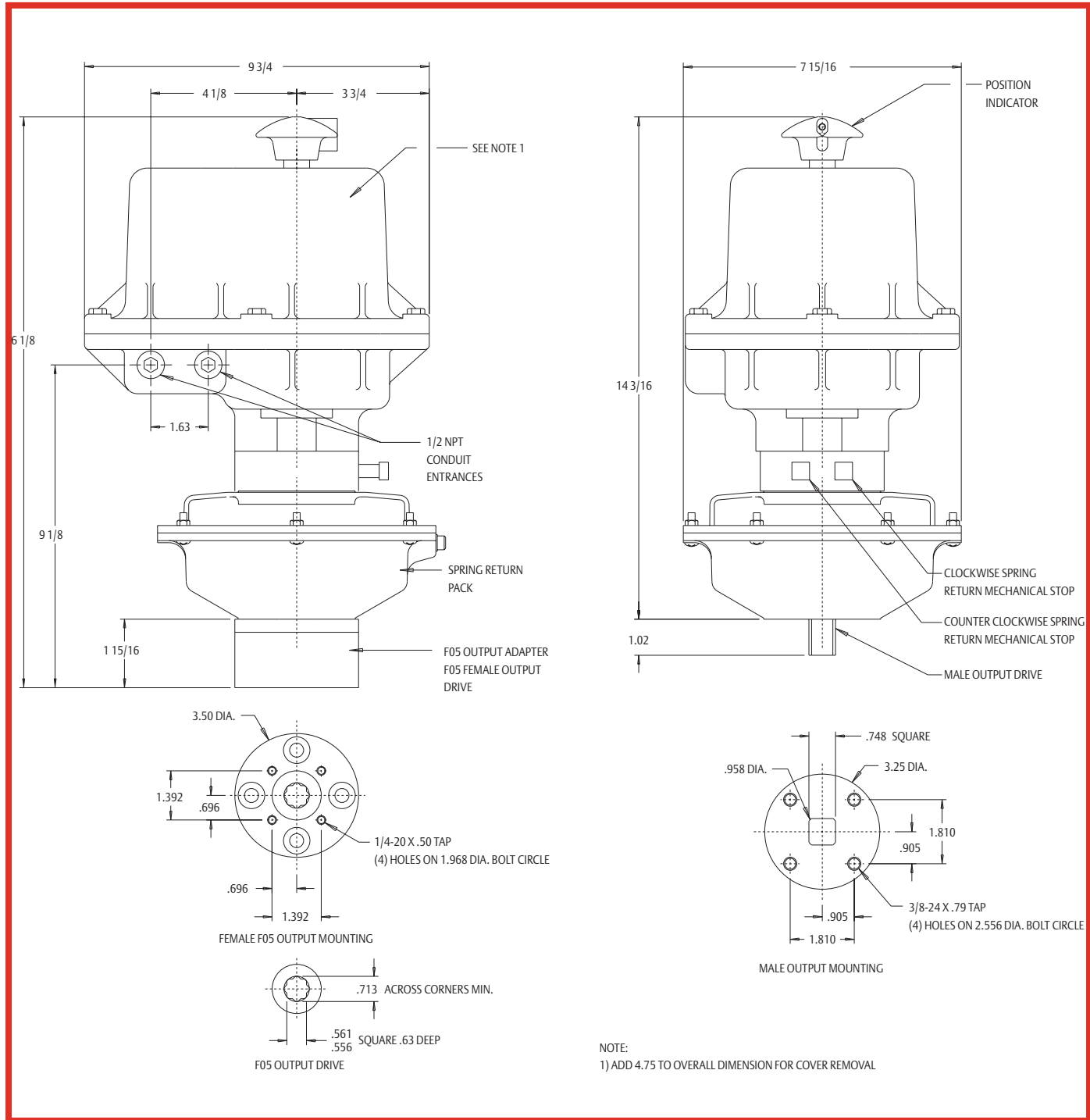

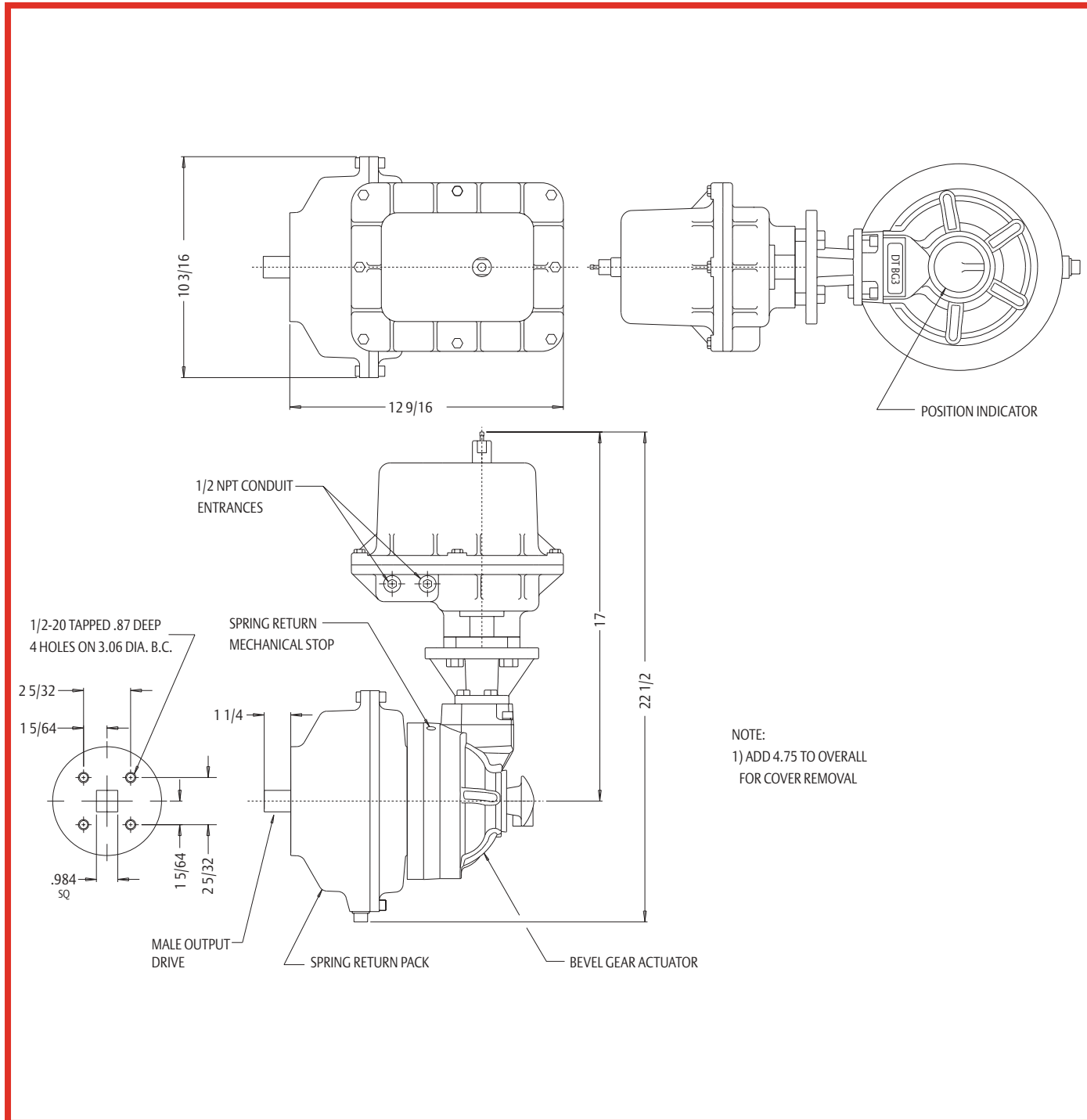

Bettis Electric

2500 Park Avenue West, Mansfield, OH 44906 U.S.A. T 419-529-4296 F 419-529-4484
 Website: www.EmersonProcess.com/Bettis E-Mail: Info.Bettis.Electric@EmersonProcess.com

INQUIRIES

Your inquiries for Bettis electric actuators can be processed efficiently when supplied with the information requested on this page. Please use this page as a guide or submittal. If you need assistance, just ask your Bettis sales representative.

Customer

Co. _____
St. _____
City _____ State _____
Zip _____
Attn: _____

Detail

Job _____
Item _____ of _____ Qty. _____
Mark/Tag _____

Valve Information

Mfg.: _____ Type: _____ Size: _____ Fig No. _____
Rotation to CLOSE Position: Clockwise Counterclockwise as viewed from above (Std. is CW)
Maximum Sizing Torque, lb-in: _____ (Safety factor included)

Actuator Information

Application: Open-Close, 2 position, Service Spring Return
 Jogging Multi-position Service Fail CW
 Automatic Modulating Service Fail CCW

Ambient Temperature: From _____ °F to _____ °F (-40°F to +140°F standard)

Nominal Operating Speed: _____ seconds per 90° (min-max range)

Motor Voltage: _____ Ph/ _____ Hz/ _____ VAC or VDC _____

Control Voltage: 1Ph/ _____ Hz/ _____ VAC (3-phase motor only)

Motor Duty Cycle: 30% or 100%

Total Number of Limit Switches: _____

Enclosure: Type 4 CSA Certified for: non-hazardous indoor and outdoor locations to protect against wind-blown dust and rain, splashing water and hose-directed water.
 Type 4 and 7 CSA Certified for: hazardous and non-hazardous indoor and outdoor locations to protect against wind-blown dust and rain, splashing water and hose-directed water plus locations classified as Class I and II, Groups C, D, E, F and G as defined in the National Electrical Code.

Integral Control Items (as required)

- Motor Brake (standard on EM-100 in 1Ph/60Hz/115VAC and all 800-Series with torques of 6,000 lb-in or greater)
- Multi-Turn Control: Set for _____ output turns (maximum of 30)
- Heater and Thermostat: 1Ph/ _____ Hz/ _____ VAC
- Three Position Operation: Set for _____ °/ _____ °/ _____ ° Stops
- Control Relay for: normally clockwise or normally counterclockwise operation and operating on 1Ph/ _____ Hz/ _____ VAC or _____ VDC
- Single Feedback Potentiometer: _____ Ohm/4 Watt
- Electronic Positioner: with 4-20mA or 0-10v or 1-5v input and set for minimum output at clockwise or counterclockwise position
- Electronic Position Transmitter: 4-20 mA output set for minimum output at clockwise or counterclockwise position

Separate Controls (as required)

- Manual Operating Station: Type 4 or Type 7 enclosure suitable for wall mounting or close coupling
- 1Ph/ _____ Hz/ _____ VAC to include:
 - (_____) Position Selector Switch marked _____ / _____ / _____
 - (_____) Push Buttons marked _____ / _____ / _____
 - (_____) Lights marked and colored _____ - _____ / _____ - _____ / _____ - _____
 - (_____) Reversing Starter with 1 Ph/ _____ Hz/ _____ VAC control voltage
- Other _____

BETTIS

EMERSON
Process Management

PRODUCT IDENTIFICATION

All Bettis TorqPlus Electric Actuators are manufactured with a product descriptive nameplate to insure its proper application and continuing identification. The following represents the typical information included on the nameplate and the meaning.

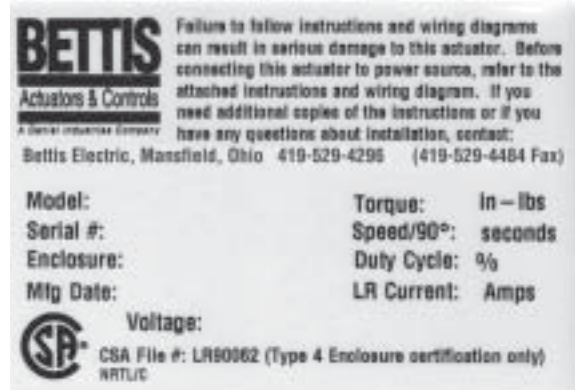

Model: Model – Operating Speed – Enclosure Type – Motor Voltage – Configuration

Torque: Rated Output Torque (lb-in)

Speed Sec 90: Seconds Per 90 Degrees Operation

Voltage: Motor Voltage (Ph/Hz/V)

LR Amps: Locked Rotor Amp Draw

Duty Cycle %: Effective Motor Run Capability

Serial: Individual Unit Serial Number

Mfg MM-YY: Month & Year of Unit Manufacturer

Enclosure: Rated Enclosure Type

DEFINITIONS

A.C. – Alternating current/voltage flowing in both directions alternately.

Ampere (Amp) – The unit of electric current, defined in terms of the force between a pair of wires.

Auxiliary Switch – A switch used to energize or de-energize other equipment (such as lights or pumps). Supplied with its own cam to synchronize other equipment at any point of travel.

Capacitor – A device having the property of storing an electrical charge.

CSA – Canadian Standards Association

D.C. – Direct current/voltage which has a constant value rated to zero. Steady current in one direction.

Duty Cycle – A mathematical calculation, expressed as a percent, to indicate available motor-on (running) time without endangering an over heating condition which would terminate actuator operation.

Using an actuator with a 10 seconds/90° operating speed and rated for a 50% duty cycle as an example, safe, non-interrupting operational periods would be: One 10 second motor-on period followed by one 10 second motor-off period. Total calculation time is 20 seconds of which 50% is motor-on time.

Proper application of the duty cycle rating allows ample time for the motor to dissipate internal heat and thereby not cause a thermal overload cutoff.

Enclosure – The housing that surrounds the actuator's operating parts. It can either be weatherproof or explosion proof. The enclosure generally protects the electrical equipment from the environment and/or prevents an explosion within the enclosure from causing an external explosion.

Hertz – Unit of frequency. Equal to one cycle per second.

NEMA – Acronym for National Electrical Manufacturers Association.

NEMA 4 – Rating designation for weatherproof enclosures. Pliable gaskets are used on all metal-mating parts to prevent moisture from entering.

NEMA 7 – Rating designation for enclosures suitable for containing internal explosion without rupturing the enclosure and without igniting surrounding gases in the atmosphere. Metal-to-metal sealing is required in these rated products.

Ohm – International unit of electrical resistance. The resistance in ohms between two points is defined by the DC voltage divided by the DC current flowing between the points.

Reversing Starter – Its purpose is to connect, disconnect and reverse electricity to the motor. Also called reversing contractor, reversing controller or integral starter.

Torque Limit Switches – Switches designed to monitor physical variables or operating states and to open circuits in the event of pre-set limits being exceeded.

Volt – Unit of potential difference or electrical potential. It represents the amount of work done per unit charge in moving a charge from one place to another.



Multi-Turn Operation

Option allows for multiple revolution on non-rising stem devices.

Electrical Mechanical Motor Brake

Available for all actuator models. Brakes are employed to eliminate motor run-on and to insure that the actuator and driven device maintain their position. Recommended applications include; all resilient seated valves, valves with high flow rates, all modulating services and any time in which increased position control is needed.

Three Position Control

Typically used for multiported valves, operation can be set for 0°-45°-90° or 0°-90°-180° with a stop at mid position from one extreme or both.

Potentiometers

Mechanically linked to the actuators output to provide a resistance signal proportional to the actuator's and driven device's position. Used to give continuous feedback to control panels, modulating position control and other closed loop devices.

Torque/Current Trip Module (for DC Motors)

- Protects the valve and actuator from excessive torque conditions by comparing the motor current with a *factory adjustable* trip value.
- Provides *dynamic braking*, in order to improve positioning accuracy at both mid and end of travel stop points. (**Caution:** A mechanical brake should also be used in conjunction with the dynamic brake feature, for applications that require the valve to be held in place after stopping.)

Control Latching Relay

- Allows the actuator to run full travel upon receiving a **non-maintained** control signal, ranging from 0-240VAC or 0-110VDC.

Control Relay

- Provides a means of opening and closing a valve with a variety of standard AC or DC **maintained** control signals, such as 120 VAC, 24 VAC, 12 or 24 VDC.
- Can be used for a *fail close* (or open) application upon *loss of the control signal*. An internal coil (designed to be continuously energized) maintains the open signal to the actuator. When the signal is removed, the coil de-energizes, causing the actuator to close.

Additional Control Options

- Up to 6 SPDT aux. limit switches
- Electronic Transmitters (4-20mA output from a DC transmitter or 4-20mA, 0-10V output from an AC transmitter)
- Dual 1k ohm potentiometers
- Two speed operation (pulse timer package)
- Unidirectional controls (up to 30 rotations)
- Control stations including buttons, lights, selector switches
- 3-phase motor controls
- Three position operation (such as 0-45-90 or 0-90-180 degrees)
- Torque seating for multi-turn and quarter turn
- Torque switch trip indication

CONTROL STATIONS



Control Stations are available in a variety of standard weatherproof wall-mounted and close-coupled configurations using the following 5-digit code system:

CS – **1st 2nd 3rd 4th 5th**

- 1st** indicates the number of pushbuttons
- 2nd** indicates the number of lights
- 3rd** indicates the number of positions on the first selector switch (such as Local-Remote)
- 4th** indicates the number of positions on a second selector switch (such as Open-Stop-Close)
- 5th** indicates close-coupled (C) or wall-mount (W)

CS-0223C would indicate **0-buttons, 2-lights, 2-position selector switch** (usually Local-Remote), **3-position selector switch** (usually Open-Stop-Close), **Close-coupled** to the actuator.

Standard configurations include:

CS-0003* CS-0223* and CS-3220*
CS-0023* CS-0203*

(* **C** for closed-coupled or **W** for wall-mount)

Typical Options

Timer packages, control relays, special labeling, LED lights, pad lockable switches, space heaters and Canadian Underwriter Laboratory labels.

Additional options for 3-phase wall-mounted CS's include starters, control transformers, and overload relays.

Remote Signal Generator



The Remote Signal Generator (**RSG**) (supplied in a wall-mounted enclosure) produces a 4-20mA output signal, by manually rotating the dial. From a remote location, this output signal can then be used to position or throttle an actuator equipped with an integral modulating board.

The RSG can also be used in conjunction with a closed-coupled "**CS**" control station.



The Bettis Electric C1397 and C1415 Servo Positioners are proportional motor controllers for actuator modulating applications. The C1397 is for actuators with AC powered split phase motors. The C1415 is for use with 12 or 24VDC powered actuators. These controls are designed to proportionally position an actuator and the driven device by comparison of a varying external input command and a mechanically linked potentiometer. Input commands can be 0-10V, 1-5V, or 4-20mA. The servo also allows for three responses to command signal loss (1-5V and 4-20mA only); fail in place, fail to full clockwise (CW) position, or fail to full counterclockwise (CCW) position.

Features and Benefits

Digital micro-control allows:

- Pushbutton programming - eliminates Span and Zero pots
- 10-bit resolution
- Off-line calibration - eliminates the need for loop calibrators

Available in multiple power supply configurations:
AC 120/230V; DC 12/24V

Onboard manual jog buttons

AC controller includes speed control

DC controller includes:

- Torque trip with relay output
- Dynamic braking for accurate stopping



Signal Wiring

4-20mA TRANSMITTER

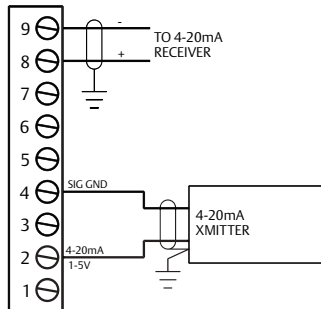

0-10V TRANSMITTER

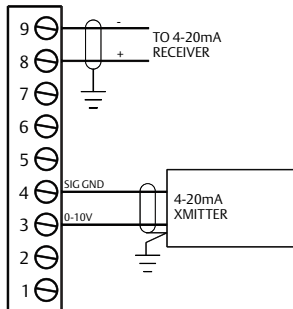

COMMAND POTENTIOMETER

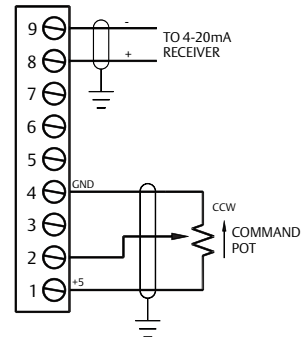

SPECIFICATIONS

Power Supply

C1397S 115VAC ± 10% 50/60Hz

C1397D 230VAC ± 10% 50/60Hz

C1415 12/24VDC Jumper configurable

Signal Inputs

All signal inputs are digitized to 10 bits of resolution.

0-10 VDC Compound Input: 200kohm input impedance.

1-5 VDC Command Input: 100kohm input impedance. Loss of signal threshold is 75% of low signal.

4-20 mA Command Input: 250ohm input impedance. Loss of signal threshold is 75% of low signal.

Feedback Input: 5 VDC excitation voltage. 1Mohm input impedance. Use with 1000ohm potentiometer.

4-20mA Output

300ohm maximum load impedance. 10-bit A/D.

Motor Outputs

C1397 When mounted in accordance with guidelines below, outputs will supply a maximum locked rotor load current (LRA) of 5A with less than 5/10mA (115/230VAC) of leakage current.

C1415 Continuous current 3A; Peak 5A.

External Fuses

C1397 Employ fusing per actuator motor LRA to a maximum of 5A.

C1415 Employ fusing per actuator motor LRA to a maximum of 5A. Consult factory for additional application details on DC powered units.

Environmental

Operating temperature: +32°F to +158°F (0°C-70°C)

Storage temperature: -40°F to +185°F (-40°C-85°C)

Relative humidity: 0 to 90% non-condensing

Function Details

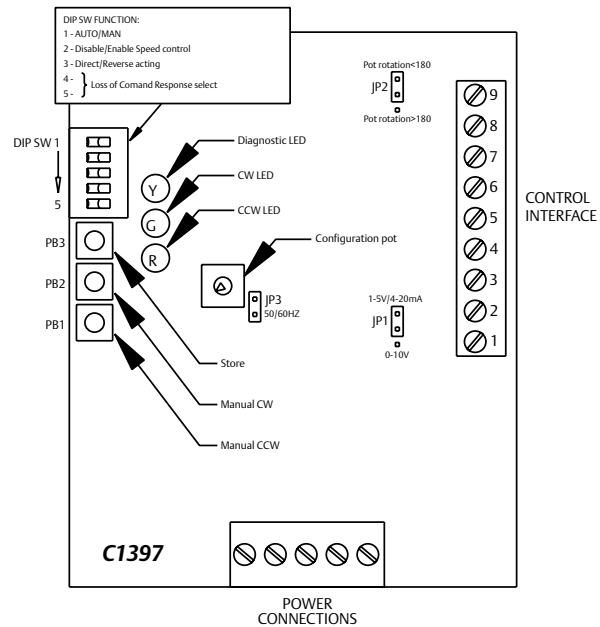
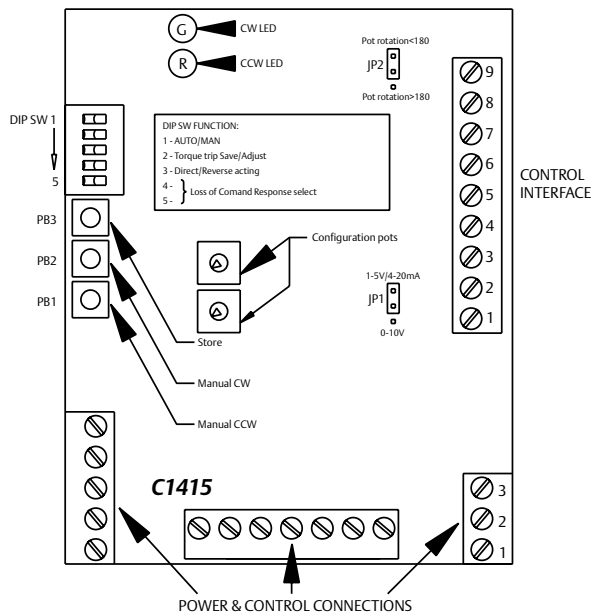

Performance Data – Open/Close and Modulating Configurations

Available Torques, Operating Speeds, Motor Duty Cycles, Motor Voltages and Locked Rotor Amp Draws

Torque Expression: Inch-Pounds (in-lb) and Newton Meters (Nm).

Speed Expression: Seconds per 90° output rotation.

Torque Output		Operating Speed Sec/90°	Model	Motor Duty Cycle	Locked Rotor Amp Draw					
in-lb	Nm				1 Phase / 50 - 60 Hz		3Ph/60Hz		Direct Current	
					115VAC	230VAC	230VAC	460VAC	12VDC	24VDC
100	11	2 <small>Note 4</small>	EM-100	30%	1.30	CF	—	—	—	—
250	28	10		30%	0.70	CF	—	—	—	—
350	39	13		30%	0.70	CF	—	—	—	—
150	17	4 <small>Note 4</small>	EM-300	30%	0.6	0.3	—	—	1.25	2.5
300	34	10		30%	0.6	0.3	—	—	1.25	2.5
400	45	15		30%	0.6	0.3	—	—	1.25	2.5
600	68	30		30%	0.6	0.3	—	—	1.25	2.5
180	20	5 <small>Note 4</small>	EM-520	30%	0.6	0.3	—	—	1.25	2.5
450	51	10		30%	0.6	0.3	—	—	1.25	2.5
600	68	15		30%	0.6	0.3	—	—	1.25	2.5
1,000	113	30		30%	0.6	0.3	—	—	1.25	2.5
350	39	5 <small>Note 4</small>	EM-500	100%	0.7	0.4	—	—	2.5	5.0
700	79	10		100%	0.7	0.4	—	—	2.5	5.0
1,000	113	15		100%	0.7	0.4	—	—	2.5	5.0
1,600	181	30		100%	0.4	0.5	—	—	2.5	5.0
325	36	2 <small>Note 4</small>	EM-510	100%	1.6	0.8	—	—	4.3	8.5
600	68	5 <small>Note 4</small>		100%	1.6	0.8	—	—	4.3	8.5
1,000	113	7 <small>Note 4</small>		100%	1.6	0.8	—	—	4.3	8.5
2,000	226	12	EM-810	100%	3.2	1.3	CF	CF	—	—
2,500	282	18		100%	3.2	1.3	CF	CF	—	—
3,500	395	30		100%	3.2	1.3	CF	CF	—	—
4,000	452	60		100%	3.2	1.3	CF	CF	—	—
3,000	339	12	EM-820	100%	3.2	1.3	CF	CF	—	—
4,000	452	18		100%	3.2	1.3	CF	CF	—	—
6,000	678	30		100%	3.2	1.3	CF	CF	—	—
7,000	791	60		100%	3.2	1.3	CF	CF	—	—
5,000	565	12	EM-830	100%	6.0	2.8	CF	CF	—	—
7,000	791	18		100%	6.0	2.8	CF	CF	—	—
10,000	1,130	30		100%	6.0	2.8	CF	CF	—	—
10,000	1,130	60		100%	6.0	2.8	CF	CF	—	—
15,000	1,695	48	EM-840	100%	6.0	2.8	CF	CF	—	—
20,000	2,260	72		100%	6.0	2.8	CF	CF	—	—
300	34	10 <small>Note 4</small>	EM-SR5	100%	0.7	0.4	—	—	—	—
400	45	15		100%	0.7	0.4	—	—	—	—
600	68	30		100%	0.4	0.5	—	—	—	—
1,600	181	90		100%	0.4	0.5	—	—	—	—

- Notes:**
1. Operating speed is nominal at rated torques. Final operating speed may vary depending on actual service.
 2. Actuators with 12VDC motors will have an operating speed of approximately 40% longer (slower) than that shown.
 3. CF – Consult Factory
 4. Bettis does not recommend the use of any actuator for any modulating application with an operating speed of 10 seconds or less.

TorqPlus™ Product Matrix

Feature		Model EM100	Model EM300	EM-500 Series	EM-800 Series	SR5 Series
Output Torque Range	in-lb Nm	100 to 350 11 to 39	150 to 600 17 to 68	180 to 1,600 20 to 181	2,000 to 20,000 226 to 2,260	300 to 1,600 34 to 181
Operating Speeds (60Hz)	Sec/90°	2 to 13	4 to 30	2 to 30	12 to 72	10 to 90
115VAC / 1Ph / 50-60Hz Motor Voltage		Standard	Standard	Standard	Standard	Standard
220VAC / 1 Ph / 50-60Hz Motor Voltage		Optional	Optional	Optional	Optional	Optional
12 or 24VDC Motor Voltage		Optional	Optional	Optional	N.A.	N.A.
CSA Certified Enclosure 4 (NEMA 4)		Standard	Standard	Standard	Standard	Standard
CSA Certified Enclosure 4&7 (NEMA 4&7)	Note 4	N.A.	Optional	Optional	Optional	Optional
CSA General Purpose Electrical Specification	Note 3	Optional	Optional	Optional	Optional	Optional
Reversible Operation, Adjustable		0 – 180°	0 – 180°	0 – 180°	0 – 180°	0 – 90°
Multi-Turn Output Control		N.A.	N.A.	Optional	Optional	N.A.
Ambient Operating Temperature -40°F to +140°F (-40°C to +60°C)		Standard	Standard	Standard	Standard	Standard
Corrosion Resistant Powder Coat Finish		Standard	Standard	Standard	Standard	Standard
Standard Manual Override Type		N.A.	Declutching	Declutching	Direct HW	N.A.
Mechanical Position Indicator		N.A.	Standard	Standard	Standard	Standard
Standard Number of SPDT Switches		2	2	2	4	2
Number of Optional SPDT Switches	Note 1	2	4	4	6	4
Dual Torque Limit Switches		N.A.	N.A.	N.A.	Standard	N.A.
Standard Conduit Entry, Number & NPT Size		(1) 1/2"	(2) 1/2"	(2) 1/2"	(2) 3/4"	(2) 1/2"
Standard Output Drive Configuration		Female DIN/ISO	Female DIN/ISO or Male	Female DIN/ISO or Male	Female Bore & Key	Female DIN/ISO or Male
Motor Brake		Standard Note 2	Optional for 15 & 30 sec Standard for 4 & 10	Optional	6000 in-lb and above – std. All others optional	Standard
Heater & Thermostat	All Voltages	Optional	Standard	Standard	Standard	Standard
Potentiometer 1k Ohm - 1/2%		Optional	Optional	Optional	Optional	Optional
Electronic Proportional Positioner and/or Electronic Position Transmitter		Optional Optional	Optional Optional	Optional Optional	Optional Optional	Optional Optional

(1) When actuator is to be supplied with potentiometer, reduce number of available optional switches by two (2) except for 100 series.

(2) Brake is part of motor rotor

(3) Actuators were subjected to an endurance test of 6000 complete cycles at maximum rated torque.

(4) Hazardous locations classified as Class I and II Groups C, D, E, F and G.

Bettis Electric Mansfield, OH U.S.A. T 419-529-4296 Website: www.EmersonProcess.com/Bettis

Bettis Electric

2500 Park Avenue West
Mansfield, OH 44906 U.S.A.
T 419-529-4296
F 419-529-4484
Website: www.EmersonProcess.com/Bettis
E-Mail: Info.Bettis.Electric@EmersonProcess.com

Bettis USA

P.O. Box 508
Waller, TX 77484 U.S.A.
T 281-463-5100
F 281-463-5103
Website: www.EmersonProcess.com/Bettis
E-mail: Info.Bettis@EmersonProcess.com

Bettis UK Ltd.

3 Furze Court
114 Wickham Rd.
Fareham, Hampshire PO 16 7SH
T 44-1329-848-900
F 44-1329-848-901

Bettis Canada Ltd.

4112-91 A Street
Edmonton, Alberta T6E 5V2
Canada
T 780-450-3600
F 780-450-1400

Bettis France:

30/36 Allee du Plateau
93250 Villemomble
France
T 331-48-122610
F 331-48-122619

Bettis Int'l Sales Office:

Calgary, Canada
Rheinberg, Germany
New Bombay, India
Singapore

Important: Due to Emerson's continuing commitment to engineered product advancement, data presented herein is subject to change.

Certified dimensional drawings and wiring diagrams are available on request. Consult factory with model designation and serial number.

Bettis Bulletin # 10.10 Rev: 02/02

© 2002 Emerson. All rights reserved. 5M/02/02

BETTIS®

EMERSON™
Process Management