

**BETTIS**<sup>®</sup>

**TorqPlus**<sup>™</sup>  
Electric Valve  
Actuators  
and Controls



**EMERSON**<sup>™</sup>  
Process Management

**EMERSON. CONSIDER IT SOLVED.<sup>™</sup>**

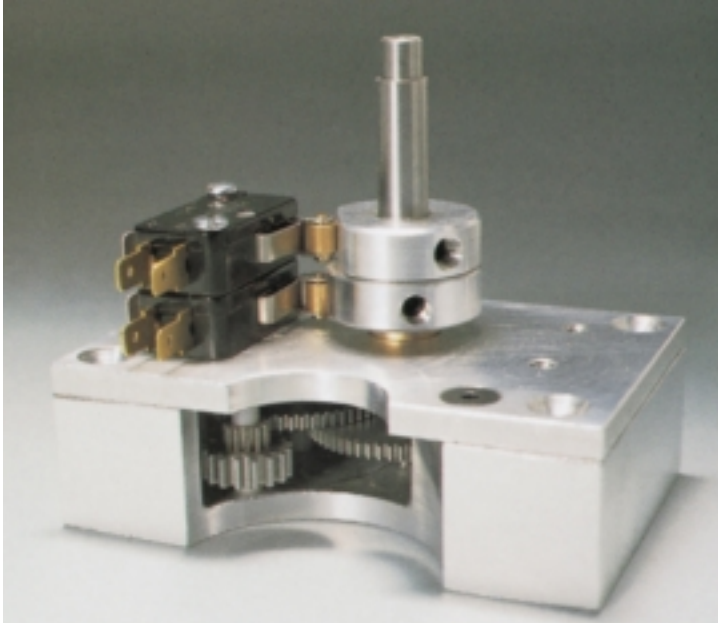

### Multi-Turn Operation

Option allows for multiple revolution on non-rising stem devices.

### Electrical Mechanical Motor Brake

Available for all actuator models. Brakes are employed to eliminate motor run-on and to insure that the actuator and driven device maintain their position. Recommended applications include; all resilient seated valves, valves with high flow rates, all modulating services and any time in which increased position control is needed.

### Three Position Control

Typically used for multiported valves, operation can be set for 0°-45°-90° or 0°-90°-180° with a stop at mid position from one extreme or both.

### Potentiometers

Mechanically linked to the actuators output to provide a resistance signal proportional to the actuator's and driven device's position. Used to give continuous feedback to control panels, modulating position control and other closed loop devices.

### Torque/Current Trip Module (for DC Motors)

- Protects the valve and actuator from excessive torque conditions by comparing the motor current with a *factory adjustable* trip value.
- Provides *dynamic braking*, in order to improve positioning accuracy at both mid and end of travel stop points. (**Caution:** A mechanical brake should also be used in conjunction with the dynamic brake feature, for applications that require the valve to be held in place after stopping.)

### Control Latching Relay

- Allows the actuator to run full travel upon receiving a **non-maintained** control signal, ranging from 0-240VAC or 0-110VDC.

### Control Relay

- Provides a means of opening and closing a valve with a variety of standard AC or DC **maintained** control signals, such as 120 VAC, 24 VAC, 12 or 24 VDC.
- Can be used for a *fail close* (or open) application upon *loss of the control signal*. An internal coil (designed to be continuously energized) maintains the open signal to the actuator. When the signal is removed, the coil de-energizes, causing the actuator to close.

### Additional Control Options

- Up to 6 SPDT aux. limit switches
- Electronic Transmitters (4-20mA output from a DC transmitter or 4-20mA, 0-10V output from an AC transmitter)
- Dual 1k ohm potentiometers
- Two speed operation (pulse timer package)
- Unidirectional controls (up to 30 rotations)
- Control stations including buttons, lights, selector switches
- 3-phase motor controls
- Three position operation (such as 0-45-90 or 0-90-180 degrees)
- Torque seating for multi-turn and quarter turn
- Torque switch trip indication

## CONTROL STATIONS



Control Stations are available in a variety of standard weatherproof wall-mounted and close-coupled configurations using the following 5-digit code system:

### CS – 1st 2nd 3rd 4th 5th

- 1st** indicates the number of pushbuttons
- 2nd** indicates the number of lights
- 3rd** indicates the number of positions on the first selector switch (such as Local-Remote)
- 4th** indicates the number of positions on a second selector switch (such as Open-Stop-Close)
- 5th** indicates close-coupled (C) or wall-mount (W)

**CS-0223C** would indicate **0-buttons, 2-lights, 2-position selector switch** (usually Local-Remote), **3-position selector switch** (usually Open-Stop-Close), **Close-coupled** to the actuator.

Standard configurations include:

CS-0003\*    CS-0223\*    and CS-3220\*  
CS-0023\*    CS-0203\*

(\* **C** for closed-coupled or **W** for wall-mount)

## Typical Options

Timer packages, control relays, special labeling, LED lights, pad lockable switches, space heaters and Canadian Underwriter Laboratory labels.

Additional options for 3-phase wall-mounted CS's include starters, control transformers, and overload relays.

## Remote Signal Generator



The Remote Signal Generator (**RSG**) (supplied in a wall-mounted enclosure) produces a 4-20mA output signal, by manually rotating the dial. From a remote location, this output signal can then be used to position or throttle an actuator equipped with an integral modulating board.

The RSG can also be used in conjunction with a closed-coupled "**CS**" control station.

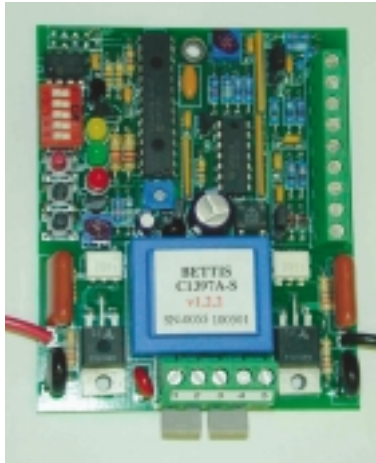

The Bettis Electric C1397 and C1415 Servo Positioners are proportional motor controllers for actuator modulating applications. The C1397 is for actuators with AC powered split phase motors. The C1415 is for use with 12 or 24VDC powered actuators. These controls are designed to proportionally position an actuator and the driven device by comparison of a varying external input command and a mechanically linked potentiometer. Input commands can be 0-10V, 1-5V, or 4-20mA. The servo also allows for three responses to command signal loss (1-5V and 4-20mA only); fail in place, fail to full clockwise (CW) position, or fail to full counterclockwise (CCW) position.

### Features and Benefits

Digital micro-control allows:

- Pushbutton programming - eliminates Span and Zero pots
- 10-bit resolution
- Off-line calibration - eliminates the need for loop calibrators

Available in multiple power supply configurations:  
AC 120/230V; DC 12/24V

Onboard manual jog buttons

AC controller includes speed control

DC controller includes:

- Torque trip with relay output
- Dynamic braking for accurate stopping

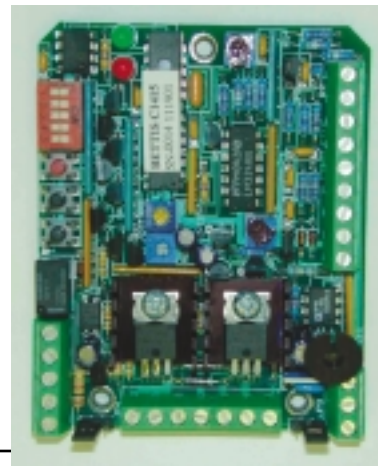

### Signal Wiring

4-20mA TRANSMITTER

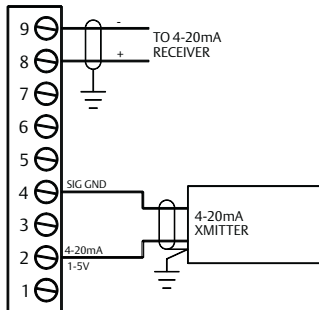

0-10V TRANSMITTER

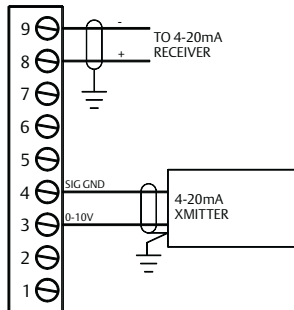

COMMAND POTENTIOMETER

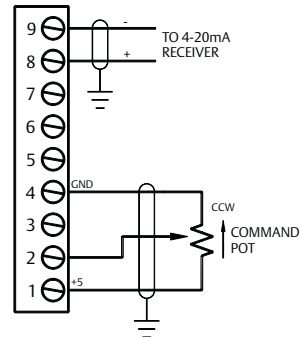

# SPECIFICATIONS

## Power Supply

**C1397S** 115VAC ± 10% 50/60Hz

**C1397D** 230VAC ± 10% 50/60Hz

**C1415** 12/24VDC Jumper configurable

## Signal Inputs

All signal inputs are digitized to 10 bits of resolution.

**0-10 VDC Compound Input:** 200kohm input impedance.

**1-5 VDC Command Input:** 100kohm input impedance. Loss of signal threshold is 75% of low signal.

**4-20 mA Command Input:** 250ohm input impedance. Loss of signal threshold is 75% of low signal.

**Feedback Input:** 5 VDC excitation voltage. 1Mohm input impedance. Use with 1000ohm potentiometer.

## 4-20mA Output

300ohm maximum load impedance. 10-bit A/D.

## Motor Outputs

**C1397** When mounted in accordance with guidelines below, outputs will supply a maximum locked rotor load current (LRA) of 5A with less than 5/10mA (115/230VAC) of leakage current.

**C1415** Continuous current 3A; Peak 5A.

## External Fuses

**C1397** Employ fusing per actuator motor LRA to a maximum of 5A.

**C1415** Employ fusing per actuator motor LRA to a maximum of 5A. Consult factory for additional application details on DC powered units.

## Environmental

Operating temperature: +32°F to +158°F (0°C-70°C)

Storage temperature: -40°F to +185°F (-40°C-85°C)

Relative humidity: 0 to 90% non-condensing

# Function Details

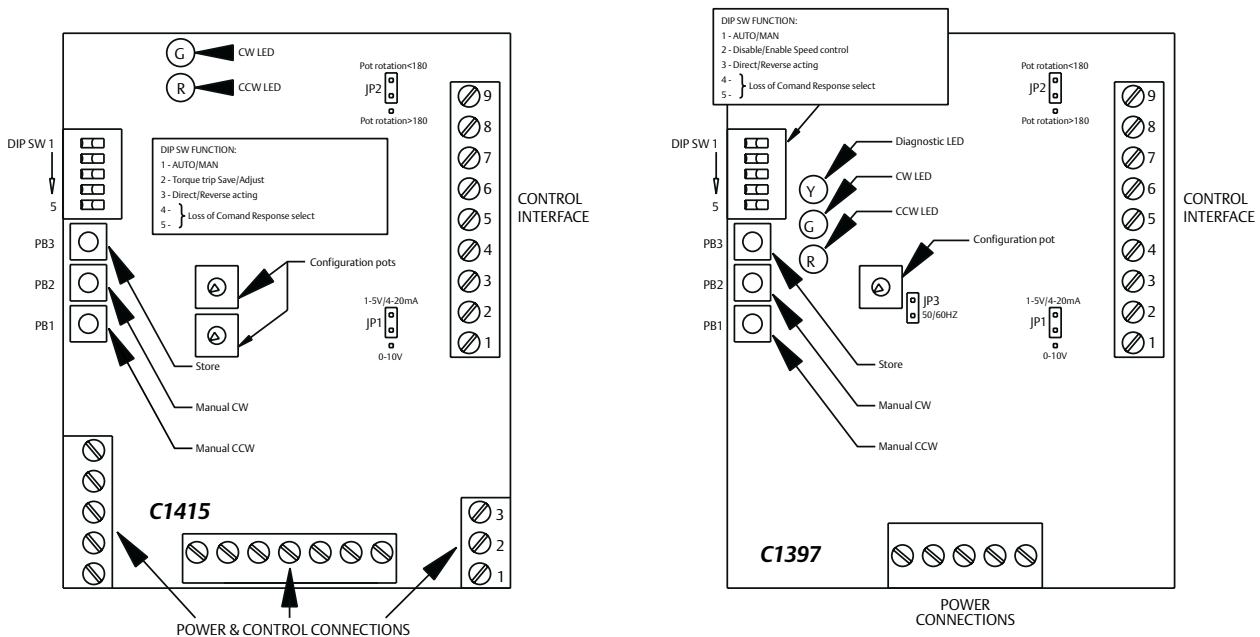

**Bettis Electric**

2500 Park Avenue West  
Mansfield, OH 44906 U.S.A.  
T 419-529-4296  
F 419-529-4484  
Website: [www.EmersonProcess.com](http://www.EmersonProcess.com)  
E-Mail: [Info.Bettis@EmersonProcess.com](mailto:Info.Bettis@EmersonProcess.com)

**Bettis USA**

P.O. Box 508  
Waller, TX 77484 U.S.A.  
T 281-463-5100  
F 281-463-5103  
Website: [www.EmersonProcess.com](http://www.EmersonProcess.com)  
E-mail: [Info.Bettis@EmersonProcess.com](mailto:Info.Bettis@EmersonProcess.com)

**Bettis UK Ltd.**

3 Furze Court  
114 Wickham Rd.  
Fareham, Hampshire PO 16 7SH  
T 44-1329-848-900  
F 44-1329-848-901

**Bettis Canada Ltd.**

4112-91 A Street  
Edmonton, Alberta T6E 5V2  
Canada  
T 780-450-3600  
F 780-450-1400

**Bettis France:**

30/36 Allee du Plateau  
93250 Villemomble  
France  
T 331-48-122610  
F 331-48-122619

**Bettis Int'l Sales Office:**

**Calgary, Canada**  
Rheinberg, Germany  
New Bombay, India  
Singapore

**Important:** Due to Emerson's continuing commitment to engineered product advancement, data presented herein is subject to change.

Certified dimensional drawings and wiring diagrams are available on request. Consult factory with model designation and serial number.

Bettis Bulletin # 10.10 Rev: 02/02

© 2002 Emerson. All rights reserved. 5M/02/02

**BETTIS®**

**EMERSON™**  
Process Management